

Operating instructions for operators and installers
Electronic index EI3



themis®plus

Contents

Electronic index EI3 1
Contents 1
Safety 1
Checking the usage 2
Installation 2
Operating the electronic index 2
Navigating within the menu 3
Service mode 5
Establishing an optical communications link 8
Setting the index parameters 8
Replacing the communication module 8
Changing the SIM card 9
Changing the battery 9
Electrical pulse output 10
Check test 10
Assistance in the event of malfunction ... 14
Accessories 14
Spare parts 14
Technical data 14
Logistics 15
Contact 16

Safety

Please read and keep in a safe place



Please read through these instructions carefully before installing or operating. Following the installation, pass the instructions on to the operator. This unit must be installed and commissioned in accordance with the regulations and standards in force. These instructions can also be found at www.docuthek.com.

Explanation of symbols

- , **1**, **2**, **3**... = Action
- ▷ = Instruction

Liability

We will not be held liable for damage resulting from non-observance of the instructions and non-compliant use.

Safety instructions

Information that is relevant for safety is indicated in the instructions as follows:

⚠ DANGER

Indicates potentially fatal situations.

⚠ WARNING

Indicates possible danger to life and limb.

! CAUTION

Indicates possible material damage.

All interventions may only be carried out by qualified gas technicians. Electrical interventions may only be carried out by qualified electricians.

Conversion, spare parts

All technical changes are prohibited. Only use OEM spare parts.

Changes to edition 12.13

The following chapters have been changed:

- Checking the usage
- Logistics

Checking the usage

Electronic index EI3 for diaphragm gas meters BK-G...B

The electronic index EI3 indicates the volume at base conditions. It can be used for reading out absolute consumption values and for retrieving consumption data for the various tariffs.

This function is only guaranteed when used within the specified limits – see page 14 (Technical data). Any other use is considered as non-compliant.

Type code

Code	Description
EI3	Electronic index based on EI3
	Variant
.00	Standard version
	Communication module
.05	ECM.05, GSM wireless technology

- ▷ The index version is shown on the index plate, see page 2 (Type label/Index plate).

Part designations

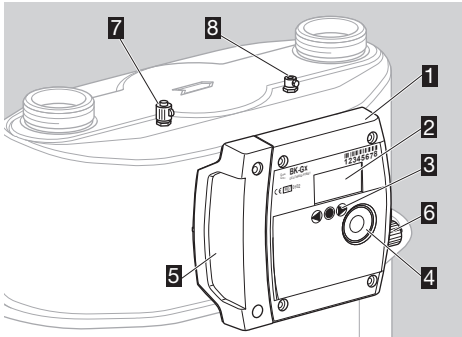

- 1 Electronic index EI3
- 2 Display
- 3 User keys
- 4 Opto-adapter interface
- 5 Service cover
- 6 Pulse output
- 7 Pressure test point with sealing sleeve (optional)
- 8 Thermowell (optional)

Type label/Index plate

Please quote for all enquiries:

- ▷ Manufacturer's serial number S/N (at the bottom left)
- ▷ Index version EI (next to the serial number)

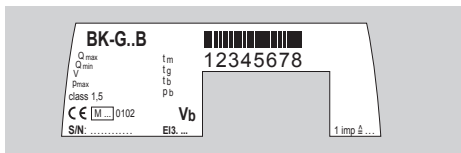

ATEX

- ▷ The electronic index is suitable for use in potentially explosive atmospheres. For the exact use (zone), see ATEX sticker on the diaphragm gas meter or see "Operating instructions for diaphragm gas meters BK-G1.6 to BK-G25" → http://docuthek.kromschroeder.com/doclib/main.php?language=1&folderid=400041&by_class=2&by_lang=-1
"Instruction Manual, Industrial Diaphragm Gas Meters Type BK-G40 · BK-G65 · BK-G100 and Type BK-G40T · BK-G65T · BK-G100T" → http://docuthek.kromschroeder.com/doclib/main.php?language=1&folderid=400045&by_class=2&by_lang=-1

Installation

Installing the gas meter

- ▷ For installing the gas meter in the pipe-work, see "Operating instructions for diaphragm gas meters BK-G1.6 to BK-G25" → http://docuthek.kromschroeder.com/doclib/main.php?language=1&folderid=400041&by_class=2&by_lang=-1
"Instruction Manual, Industrial Diaphragm Gas Meters Type BK-G40 · BK-G65 · BK-G100 and Type BK-G40T · BK-G65T · BK-G100T" → http://docuthek.kromschroeder.com/doclib/main.php?language=1&folderid=400045&by_class=2&by_lang=-1

Operating the electronic index

- ▷ The display on the index is switched off.
- Briefly press any key.



Home key

- ▷ A beep sounds and the main screen appears.

Main screen

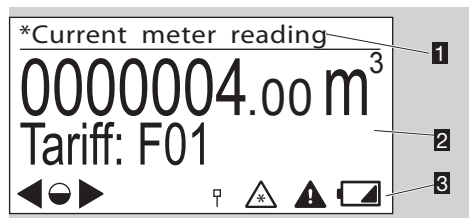

- 1 Menu area
- 2 Information area
- 3 Status line (symbols)

User keys, selection key and symbols

- ▷ You can navigate through the menu using the user keys ►, ◀ and the selection key ●.

Symbol	Meaning
►, ◀	Navigate to the left or the right on each level using the user keys.
●	Briefly pressing the selection key selects a sub-menu. Holding the selection key pressed down switches the display back to the previous menu.
◐	Briefly pressing the selection key selects a sub-menu.
◑	Holding the selection key pressed down switches the display back to the previous menu.
▷, ○, ◀	Keys inactive
Ⓜ	RF module/communication is active
Ⓜ	RF module/communication is inactive
Ⓜ	RF communication—pairing successful
⚠	Invalid data
⚠	Alarm
🔋	Low index battery. This symbol is only displayed when battery power is low.
⚠	Temperature out of operational range
⚠	Pressure out of operational range
⚠	Multiple sensor data out of operational range

- ▷ In each menu, the meaning of the symbols for the keys is described in the information area.
- ▷ In the main screen under “General instructions”, all the symbols are explained.

Navigating within the menu

- ▷ The menu is constructed hierarchically.
- ▷ The “Current meter reading” main screen appears when switching on the index.
- ▷ If you are in a different menu, the display will automatically change back to the main screen when no user key has been pressed for 30 s, and switches off after a further 30 s.
- ▷ You can navigate from the main screen to the various menus, such as “Date and time (UTC)” using the user keys ►, ◀.

Menu overview

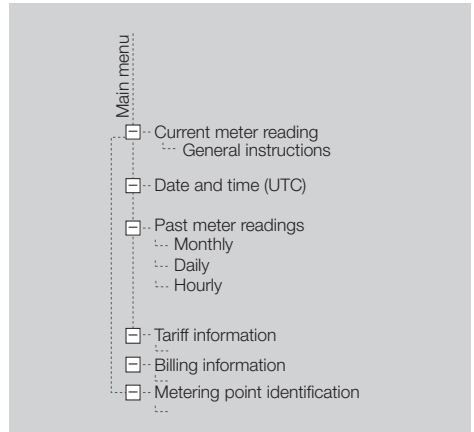

Current meter reading

- ▷ The absolute meter reading and optionally the current tariff are indicated in the main screen.
- ▷ This appears when switching on the index.
- ▷ You can receive information about the symbols by pressing the selection key ● and the user keys ►, ◀, or see page 3 (User keys, selection key and symbols).

Date and time (UTC + X)

- ▷ UTC = coordinated universal time + X = offset for conversion to local time.
- ▷ Information on the date and time display.
- ▷ The current date and time appears when the selection key ● is pressed.
- ▷ Local time is supported.
- ▷ Daylight saving time can be supported.
- ▷ For further information, contact the meter operator.

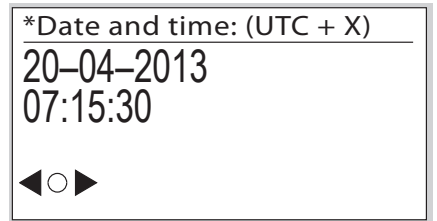

- ▷ The date is given in the format DD-MM-YYYY.

Past meter readings

- ▷ Consumption data dating as far back as 20 weeks can be called up.
- ▷ By pressing the selection key ●, consumption data are displayed, which are given by month, day or hour intervals:
M: monthly
D: daily
H: hourly

- ▷ “hourly summary” example:

```
*H: 01-05-13 18:00->19:00
0000000.00->0000004.00m3
Vb          4.00m3
Tariff: F02
◀●▶
```

- ▷ The timeframe is displayed with date and time for the start and end of the period.
- ▷ The meter reading is displayed for the start and end of the period in m³.
- ▷ The consumption for this period is indicated in m³.
- ▷ The tariff (e.g. F02) may be displayed.
- ▷ The ⚠ symbol is displayed if, for example, the tolerance between the internal time recording and the actual time is too large. This can lead to invalid consumption data. After the next time synchronization, the consumption data are recorded again correctly and ⚠ disappears.

Tariff information

```
Tariff information
Tariff program &
Details
◀●▶          ⚠
```

- ▷ This menu contains information on the current tariff program.
- ▷ By briefly pressing the selection key, you can access further information. Here, the active tariff program is displayed, as are the date and time of activation.

```
Tariff information
ID :Green Spring Demo

From : 01-01-2000    06:00

◀●▶
```

- ▷ By briefly pressing the selection key, you can visualize the consumption data.

```
Consumption results
F01:      0.00m3
F02:      0.00m3
F03:      0.00m3
UES:0x0240000000000000
◀●▶
```

- ▷ In lines F01 to F03, the current absolute gas consumption values of the relevant tariff register are displayed.
- ▷ In the “UES” (UNI-TS 11291 event status) field, the current diagnostic information is displayed.
- ▷ The data are updated hourly.

Billing information

```
Billing information
Current &
previous billing
◀●▶          ⚠
```

- ▷ This menu provides further information on the gas consumption values within the periods in the register.
- ▷ By briefly pressing the selection key, you can visualize the overview of the saved billing periods.

```
Billing information (1/5)
ID :SPIDER NET

From :01-01-2000    06:00
To   :01-01-2000    03:26

◀●▶
```

- ▷ At this menu level, you will find the identification and the scope of validity (length of time) of the relevant billing period.
- ▷ By pressing the ▶, ◀ keys, you can change between the current billing period and the last four billing periods.
- ▷ By briefly pressing the selection key, you can visualize the relevant consumption data.

```
Billing information (1/5)
Vb :      4.00 m3
F01 :      0.00m3
F02 :      0.00m3
F03 :      0.00m3
UES:0x0240000000000000
◀●▶
```

- ▷ V_b is the absolute value of the gas meter reading.
- ▷ In lines F01 to F03, the absolute values of the tariff registers are displayed.
- ▷ In the “UES” (UNI-TS 11291 event status) field, the current diagnostic information is displayed.
- ▷ All figures are absolute values, which are saved at the end of the relevant billing period.
- ▷ The data for the current billing period are updated hourly.

Service mode

Part designations

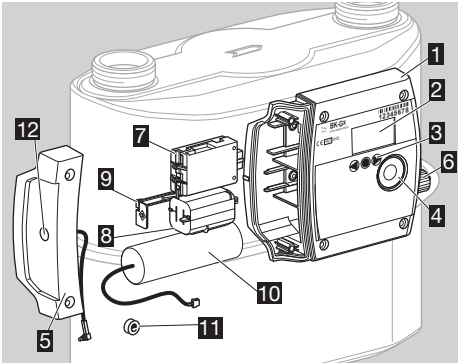

- 1** Electronic index EI3
- 2** Display
- 3** User keys
- 4** Opto-adaptor interface
- 5** Service cover
- 6** Pulse output
- 7** Communication module
- 8** Battery for the index
- 9** Protection clip
- 10** Battery for the communication module
- 11** Installer seal
- 12** Connection for external antenna (option)

- ▷ In Service mode, meter-specific operating data can be called up.

Activating Service mode

- 1** Hold the selection key ● pressed down.
- ▷ A pixel will appear in each corner of the display.
- 2** Observe one pixel: while the pixel is visible, hold the selection key ● pressed down. Release the key as soon as the pixel has disappeared.
- 3** Repeat the process, until all the pixels are off and “Test instructions” appears in the menu area.
- ▷ Service mode is activated.

Service mode menu overview

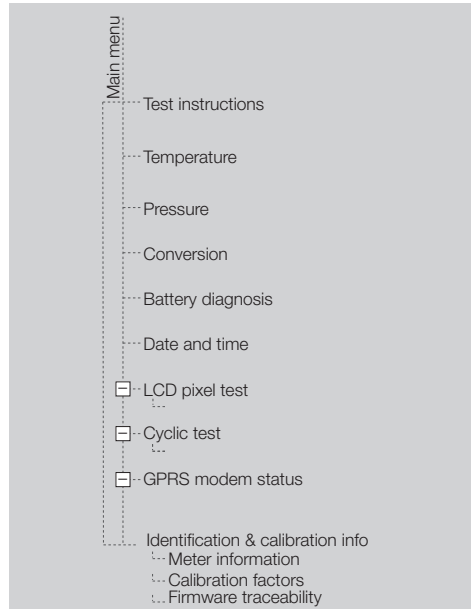

Test instructions

Test instructions

Automatic return to main menu after 5 minutes of inactivity

Hold ● on any screen to return immediately



Temperature

- ▷ The current gas temperature is displayed.

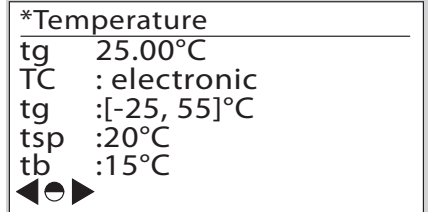

- tg: currently measured gas temperature
- TC: type of temperature conversion
Electronic: mathematical conversion to t_b in index
- t_g : [] max. allowable gas temperature range
 t_g [min. value, max. value]
- t_{sp} : specified centre temperature (in accordance with EN 1359)
- t_b : base temperature (in accordance with EN 1359), see page 14 (Technical data)

- ▷ Check test for temperature measurement, see page 10 (Check test).

Pressure

- ▷ The current pressure data will be displayed.

```
*Pressure
pg 1013.25mbar
PC :electronic
pg :[800.00, 1600.00]mbar
pb :1013.25mbar
```



- pg actual absolute gas pressure inside the meter
- PC: electronic – type of pressure conversion
- pg: [] max. allowable gas pressure range p_g [min. value, max. value]
- pb: base pressure (in accordance with EN 1359)
- ▷ Check test for pressure measurement, see page 13 (Pressure test).

Conversion

- ▷ The conversion values are displayed.

```
Conversion
Va 0000000.00m³
Cf 00.9455660
pg 1013.25mbar
tg 25.00°C
Vb 0000000.00m³
```



- Va volume alarm conditions
- Cf conversion factor Cf = $(p_g / p_b) \times (T_b / T_g) \times (Z_b / Z)$ with $Z_b / Z = 1$
- pg actual absolute gas pressure inside the meter
- tg actual gas temperature
- Vb volume at base conditions

Battery diagnosis

- ▷ When the battery is connected, the status "OK" is shown in the display.

```
Battery diagnosis
U(battery) 3.60 V

Status : OK
```



Date and time

- ▷ Information on the date and time display.

```
* Date and time
10-01-2011
10:02:06
```



- ▷ The operator can transfer the switchover between winter and summer time to the communication module, provided that it supports this.
- ▷ The date is given in the format day - month - year.
- ▷ The date format can differ depending on the market.
- ▷ This display is only visible if access to the past meter readings has been activated.

LCD pixel test

- ▷ A display test can be carried out in this menu.

- 1 Follow the displayed instructions.
- ▷ A test pattern is shown in the display.
- 2 Briefly press the selection key ●.
- ▷ A further test pattern appears in the display.
- 3 Hold the selection key pressed down. The display switches to the previous menu.

Cyclic test

- ▷ The accuracy of the meter can be checked using a cyclic test.

```
*Cyclic test: Starting
C 000.00000 m³
U 000.00000 m³
tg 25.04°C pg 1023.25mbar
N 00000-0 t 00000.00s
Press ● to abandon test
```

- C converted volume (temperature and pressure)
- U non-converted volume
- tg gas temperature
- pg gas pressure (absolute)
- N number of complete measuring cycles (measuring unit revolutions) – number of intermediate sampling points in the measuring cycle (max. 8)
- t total testing time in seconds
- 1 Briefly press the selection key ● in order to start the measurement. A beep confirms the start of the measurement.
- ▷ The display is visible for the first 5 minutes. It then disappears but lights up every minute for 10 seconds.

- ▷ In order to end the measurement, briefly press the selection key ● again. Measurement stops once the full number of measuring unit revolutions has been completed.
- ▷ Measurement is terminated automatically after 5 hours.
- ▷ A beep indicates that measurement has ended.
- 2 Read off the measurement results.
- ▷ Check test for cyclic test, see page 10 (Check test).

GPRS modem status

- ▷ The communication data are displayed.

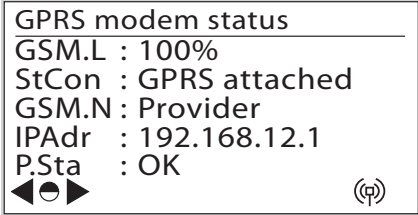

- GSM.L: GSM reception level
The reception level between 1–31 is transferred to a percentage value between 3 and 100%.
- StCon: Connection status
GSM attached: comms module is switched on
GSM not attached: comms module is switched off
- GSM.N: GSM network operator
The name of the current provider is displayed in clear text.
- IPAdr: IP address is displayed
- P.Sta: PIN status: OK
PIN status: Failed
- ▷ For symbols, see page 3 (User keys, selection key and symbols).
- ▷ Depending on the GPRS reception level (see display), the use of an internal or an external antenna is possible. The internal antenna is the standard. In order to use an external antenna, the service cover has to be exchanged by one with an SMA connector.

Identification & calibration info

Meter-specific technical data are displayed in sub-menu by pressing the user keys ▶, ◀ and the selection key ●.

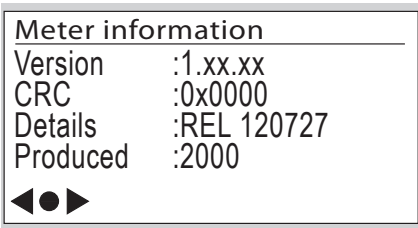

Meter information:

- Software version
- CRC: software checksum
- Software details
- Year of manufacture
- ▷ Other screen descriptions (not illustrated):

Calibration information:

- Meter calibration parameters Q1 to Q3 (adjustment values Q1 to Q3 for three-point calibration)

Meter characteristics:

- Cyclic meter volume
- Transitional flow rate
- EN 1359 Reg. No.: NG-4701BM0443 (example)

Ambient conditions:

- Electromagnetic
- Mechanical

Firmware traceability

- ▷ The events shown are saved in the non-volatile permanent log memory.
- ▷ The metrology-relevant system events, e.g. firmware upgrades, restarts, low voltage, etc. are stored in the permanent log memory.
- ▷ The events in the permanent log have unique numbers, e.g.:
2 → Firmware upgrade
15 → Restart demand
16 → Restart
- ▷ Only events which are relevant for the firmware history are listed in the “Firmware traceability” sub-menu.

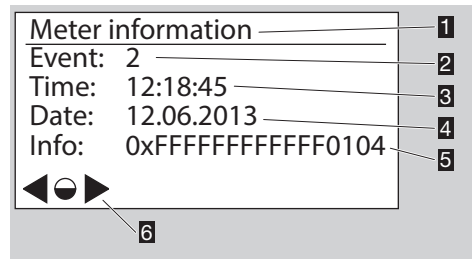

- 1 Menu description
- 2 Event: event that has occurred; can be assigned the number 2, 15 or 16
- 3 Time: time at which the event occurred
- 4 Date: date on which the event occurred
- 5 Info: additional data, as explained below
- 6 Navigation symbols

In the case of event 2, “Firmware upgrade”, the meaning of the additional data is as follows:

Date: 12.06.2015
Info: 0xFFFFFFFF0104

Additional manufacturer-specific data

Reason:
 00: upgrade started;
 01: upgrade completed;
 02: upgrade failed/error;
 03: upgrade rejected

The user ID (HEX coded; here 0x04) means:
 First position (1st nibble/here 0) contains the information for the communication port:
 0: unknown;
 8: GSM modem;
 9: opto-port.
 Second position (2nd nibble/here 4) contains a unique user ID 0 to F, e.g. 6 => manufacturer; further information is to be requested from the meter owner.

In the case of event 15 “Restart demand” and event 16 “Restart”, the meaning of the additional data is as explained below:

- ▷ The HEX values must always be itemized in pairs (1 byte).
- ▷ The HEX values of the firmware version are displayed “LSB first” coded.
- ▷ LSB first: least significant byte first.
- ▷ MSB first: most significant byte first.

Date: 12.06.2015
Info: 0xXXXX 7DFE 1D150104

Additional manufacturer-specific data

Checksum (CRC), e.g.:
 0x7DFE (MSB first coded)

Version information, e.g.:
 0x1D1501 (display: LSB first)
 => 0x01151D (HEX, MSB first coded)
 => 01.21.29 (DEC, MSB first coded)

The user ID (HEX coded; here 0x04) means:
 First position (1st nibble/here 0) contains the information for the communication port:
 0: unknown;
 8: GSM modem;
 9: opto-port.
 Second position (2nd nibble/here 4) contains a unique user ID 0 to F, e.g. 6 => manufacturer; further information is to be requested from the meter owner.

Establishing an optical communications link

- ▷ In order to configure the electronic index for the respective application, the optical communications link must be activated.
- 1** Position the opto-adapter head on the interface provided.

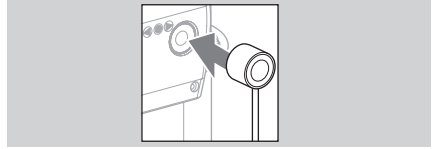

- 2** Press any user key.
 - ▷ Optical communication is enabled for 1 minute.
 - ▷ If the optical communications link is not used during this time, the interface will be deactivated.
- 3** Initiate communication.
 - ▷ The procedure depends on your user software.

Setting the index parameters

- ▷ The index parameters can be adjusted using the user equipment. Please contact manufacturer.

Replacing the communication module

⚠ WARNING

Risk of explosion in explosion-hazard areas!

- As a general rule, maintenance and repair work should be avoided in explosive atmospheres.
 - Check that the electrical system complies with the special electrical explosion protection requirements.
 - When working on electrical equipment in an explosion-hazard area, only design-approved electrical operating equipment may be used.
 - Use original spare parts supplied by Elster GmbH, see page 14 (Spare parts).
- ▷ When changing the SIM card together with the communication module or just exchanging the SIM card, the optical communications link has to be established, see page 8 (Establishing an optical communications link).
 - ▷ For safe handling in an explosion-hazard area, the order of the following steps has to be ensured.

Replacing the communication module

▷ TORX screw driver size T20 required.

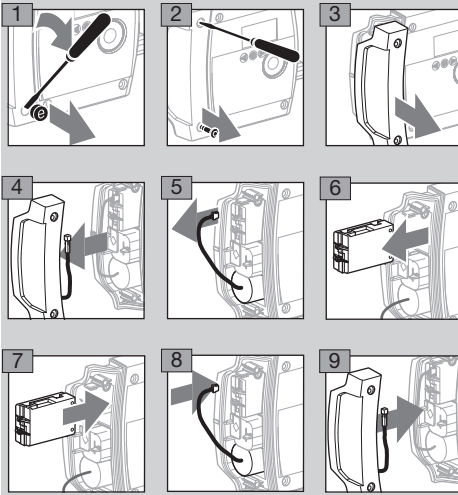

- 10 Replace the service cover on the electronic index.
- 11 Push in a new screw locking cap, see page 14 (Spare parts). The body carrying out this task should apply its own adhesive seal for sealing the service cover.

Changing the SIM card

- 1 Establish the optical communications link, see page 8 (Establishing an optical communications link).
- 2 Follow steps 1 to 6 of “Replacing the communication module”, see section above.
 - ▷ The SIM card slot can be found on the underside of the module.
- 3 Briefly press the SIM card to remove it from the holder.
- 4 Insert the new SIM card in the same position and lock it by pressing briefly.
- 5 To reinstall the communication module, follow steps 7 to 11 of “Replacing the communication module”, see section above.
 - ▷ The new SIM card requires a new PIN number.
- 6 Enter the new PIN number via the optical interface. The procedure depends on your user software.

⚠ WARNING

Risk of losing data!

- Before changing the SIM card, ensure that the GSM connection is not active!

Changing the battery

⚠ WARNING

Risk of explosion in explosion-hazard areas!

- As a general rule, maintenance and repair work should be avoided in explosive atmospheres.
- Check that the electrical system complies with the special electrical explosion protection requirements.
- When working on electrical equipment in an explosion-hazard area, only design-approved electrical operating equipment may be used.
- Use original spare parts supplied by Elster GmbH, see page 14 (Spare parts).

- ▷ The battery is available as a spare part, see page 14 (Spare parts).
- ▷ Prepare the index for changing the batteries.
- ▷ TORX screw driver size T20 required.

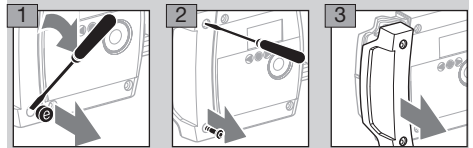

Battery for the communication module

- ▷ The battery can only be replaced when no data communication is taking place (check for the RF module symbol in the display). Otherwise, data communication will be cut off.

Replace the battery as shown in the following steps:

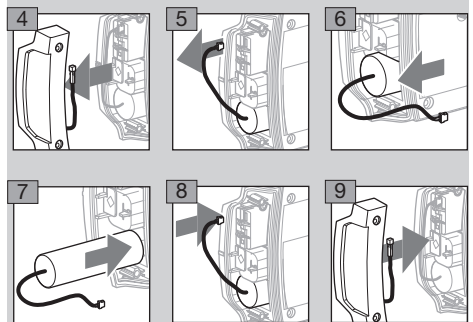

- 10 Reprogram the battery parameters via the optical interface.
 - ▷ The procedure depends on your user software.
- 11 Replace the service cover on the electronic index.
- 12 Push in a new screw locking cap, see page 14 (Spare parts). The body carrying out this task should apply its own adhesive seal for sealing the service cover.

Electrical pulse output

⚠ WARNING

Risk of explosion in explosion-hazard areas!

- As a general rule, maintenance and repair work should be avoided in explosive atmospheres.
- Check that the electrical system complies with the special electrical explosion protection requirements.
- When working on electrical equipment in an explosion-hazard area, only design-approved electrical operating equipment may be used.
- This pulse output is **not** suitable for metrological testing purposes, but for monitoring the consumption.

- ▷ The generated pulses correspond to the values shown in the technical data, see page 14 (Technical data).
- ▷ When gas consumption is higher than the output can transmit its pulses, the pulses are buffered and will be transmitted afterwards when consumption is low.

Pin assignment:

Pin 1, 2, 4, 6: not connected

Pin 3: output +

Pin 5: output -

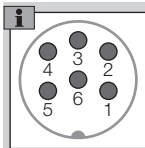

- ▷ To connect the pulse output, use a socket type IEC 60130-9.

Check test

Directive 2014/32/EU (MID) prescribes that it must be possible to check the meter.

- ▷ The requirements and test methods must comply with national laws and regulations.
- ▷ The following tests describe the check tests which are carried out by accredited testing agencies.
- ▷ Always conduct a pressure and temperature correction in accordance with established procedures (unit under test against master meter).
- ▷ Measurement accuracy class, see page 14 (Technical data).
- ▷ The unit under test must be acclimatized and installed on the test rig.
- ▷ Maintain the climatic conditions constant during the entire test duration. Otherwise, the test results will be inaccurate.
- ▷ Immediately before commencing the test, pass the quantity of test air, which corresponds to at least 50 times the cyclic volume of the unit under test, through the meter at a flow rate of Q_{\max} (maximum flow rate of a gas meter).

- ▷ To conduct the tests, the thermowell and the pressure test point (if available) can be used as a reference for the temperature and pressure measured by the index.

Cyclic test

The manual test is described below.

Legend

Δt_N = total master meter testing time in s

Δt_P = testing time of the unit under test in s

Q_{\max} = maximum flow rate of a gas meter

Q_{\min} = minimum flow rate of a gas meter

Q_N = flow on master meter in m^3/h based on the displayed volume V_N

$Q_{\text{act},N}$ = actual flow rate on master meter in m^3/h

Q_P = flow determined on unit under test based on V_P in m^3/h

V_N = displayed volume on master meter in m^3

$V_{\text{act},N}$ = actual volume having flowed through the master meter in m^3

V_P = displayed volume on unit under test in m^3
Value after C or U in display, depending on device configuration and test method.
See test procedure below for further details.

F_N = error of the master meter in %

F_P = error of the unit under test in %

p_N = absolute pressure on the master meter in mbar

p_P = absolute pressure on the unit under test in mbar

T_N = absolute temperature on the master meter in K

T_P = absolute temperature on the unit under test in K

t_b = base temperature in $^{\circ}\text{C}$

V_b = converted volume with reference to t_b and p_b

p_b = base pressure in mbar

Cyclic test at a constant flow rate

- ▷ The test rig is in pre-trial operation.
- ▷ Maintain the flow rate constant.

Test load and minimum test volumes for the test with index readout:

Type	Q_{\max} in m^3/h	Cyclic volume in dm^3	Test volume in dm^3 at		
			Q_{\min}	$0.2 Q_{\max}$	Q_{\max}
BK-G6	10	6	6	60	300
BK-G10	16	6	6	60	300
BK-G16	25	6	6	60	300
BK-G25	40	12	12	120	600
BK-G40	65	18	18	180	900

- ▷ The minimum test volumes are recommended guide values. The measurement uncertainty of the complete system (test rig plus unit under test) must not exceed 1/3 of the maximum permissible error (MPE). The testing time must be at least 10 s.

- ▷ In the test procedure described below, it is guaranteed that the unit under test always performs full measuring unit rotations.

Master meter test procedure

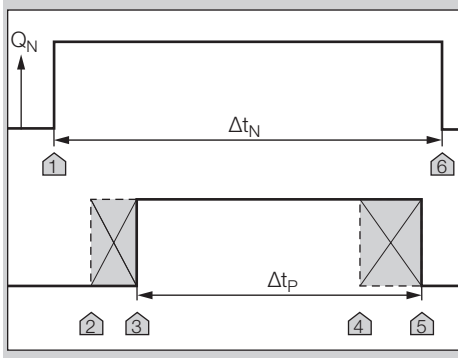

- 1 Set the test flow rate.
- 2 Start measuring the reference time Δt_N at marker 1.
- 3 Immediately afterwards, briefly press the selection key ● on the index to start the cyclic test on the unit under test – marker 2. The index will thus be “armed” for measurement.
 - ▷ As soon as one of the significant sensor positions has been detected, the unit changes to measuring mode – marker 3. A beep confirms the start of the measurement.
 - ▷ Once the required minimum testing time has been reached, the measurement can be terminated – marker 4.
- 4 Briefly press the selection key ● in order to end the measurement.
 - ▷ Measurement on the unit under test stops automatically once the full number of measuring unit revolutions has been completed – marker 5.
 - ▷ A beep acknowledges the end of the measurement.
 - ▷ Measurement is terminated automatically after 5 hours.
- 5 Stop the test on the master meter – marker 6.
 - ▷ The measurements are then available.
- 6 Read off the flow rate on the master meter or calculate if necessary:
 - a) taking into account the inherent error of the master meter:

$$Q_{act,N} = V_N \times 3600 \text{ s/h} / ((1+F_N/100) \times \Delta t_N)$$
 - b) If the inherent error of the master meter has already been taken into account in the displayed volume ($V_N = V_{act,N}$):

$$Q_{act,N} = V_{act,N} \times 3600 \text{ s/h} / \Delta t_N$$
- 7 Calculate the flow rate on the unit under test:

$$Q_P = V_P / \Delta t_P$$
- 8 The accuracy is checked by comparing the flow rates. The pressure and temperature values of the unit under test corrected with reference to

the master meter have already been taken into account here:

$$F_P = 100\% \times (((Q_P \times p_P \times T_N) / (Q_{act,N} \times p_N \times T_P)) - 1)$$

The following applies:

$$T_P = (273.15 + \{t_g\}) \text{ K}$$

$$p_P = \{p_g\} \text{ mbar}$$

If Q_P in step 7 is determined from the non-converted volume V_P , the following applies:

$$T_P = (273.15 + \{t_g\}) \text{ K}$$

where t_g = relevant gas temperature on the unit under test in °C (display)

- ▷ The curly brackets mean “numerical value of”.
- ▷ On a nozzle test rig with a known flow rate, steps 2 and 6 can be omitted.
- ▷ The error calculation is based on PTB Testing Instructions, Volume 29: “Messgeräte für Gas – Gaszähler” (Measuring instruments for gas – gas meters), Edition 2003.

Cyclic test with a given volume

Test load and minimum test volumes for the test with index readout:

Type	Q_{max} in m^3/h	Cyclic volume in dm^3	Test volume in dm^3 at		
			Q_{min}	$0.2 Q_{max}$	Q_{max}
BK-G10	10	6	180	360	360
BK-G16	16	6	180	360	360
BK-G16	25	6	180	360	360
BK-G25	40	12	360	720	720
BK-G40	65	18	540	1080	1080

Master meter test procedure

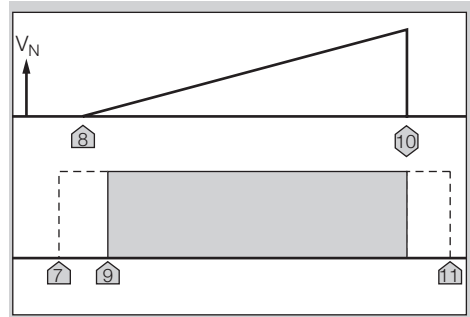

- 1 To activate the cyclic test on the unit under test, briefly press the selection key ● on the index – marker 7. The index will thus be “armed” for measurement.
- 2 Start the test on the master meter – marker 8.
 - ▷ As soon as one of the significant sensor positions has been detected, the unit changes to measuring mode – marker 9.
- 3 Test is ended – marker 10.
- 4 Read off the test results on the unit under test.
 - ▷ The measured values are updated with each 1/8 revolution of the measuring unit.

- 5** Compare the measurement results with the master meter and determine the measuring deviation on the unit under test:

- a) taking into account the inherent error of the master meter:

$$F_P = 100\% \times \left(\frac{(V_P \times (1 + F_{N/100}) \times p_P \times T_N)}{(V_N \times p_N \times T_P)} - 1 \right)$$

- b) If the inherent error of the master meter has already been taken into account in the displayed volume ($V_N = V_{act,N}$), the following applies:

$$F_P = 100\% \times \left(\frac{(V_P \times p_P \times T_N)}{(V_{act,N} \times p_N \times T_P)} - 1 \right)$$

- ▷ The following applies:

$$T_P = (273.15 + \{t_g\}) \text{ K}$$

$$p_P = \{p_g\} \text{ mbar}$$

If the non-converted volume V_P is taken for V_P :

$$T_P = (273.15 + \{t_g\}) \text{ K}$$

where t_g = relevant gas temperature on the unit under test in °C (display)

- ▷ The curly brackets mean "numerical value of".
- 6** Stop execution of the cyclic test – marker 11. Briefly press the selection key **●** twice in order to stop the measurement.
- ▷ A beep confirms interruption of the measurement.
- ▷ Measurement is terminated automatically after 5 hours.
- ▷ The error calculation is based on PTB Testing Instructions, Volume 29: "Messgeräte für Gas – Gaszähler" (Measuring instruments for gas – gas meters), Edition 2003.

Pulse test (optical interface)

Test load and minimum test volumes for the test with index readout:

Type	Q_{max} in m^3/h	Cyclic volume in dm^3	Test volume in dm^3 at		
			Q_{min}	$0.2 Q_{max}$	Q_{max}
BK-G6	10	6	180	360	360
BK-G10	16	6	180	360	360
BK-G16	25	6	180	360	360
BK-G25	40	12	360	720	720
BK-G40	65	18	540	1080	1080

- ▷ Pulse value V_{Imp} , see page 14 (Technical data).
- ▷ This test can only be carried out when the optical communications link has been established. The procedure depends on your user software.

- 1** Establish the optical communications link, see page 8 (Establishing an optical communications link).
- 2** Interrupt communication to the installed communication modules before starting the test so that the measurement accuracy will not be adversely affected.

Pulse test at a constant flow rate (optical interface)

Master meter test procedure

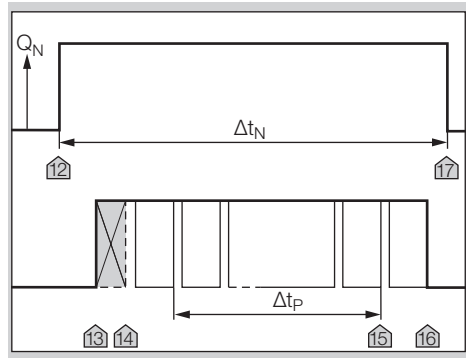

- 3** Set the test flow rate.
- 4** Start measuring the reference time Δt_N at marker 12.
- ▷ Marker 12 indicates the release of the test flow rate on the master meter.
- 5** Immediately afterwards, start the pulse test on the unit under test – marker 13.
- ▷ Then the unit under test generates the volume pulses on the optical interface each time the lowest-order decimal place on the meter display is incremented – marker 14. The test begins.
- 6** As soon as the required minimum test volume has been reached on the unit under test, the time measurement on the unit under test can be stopped – marker 15.
- 7** End the pulse test using any command – marker 16.
- ▷ Measurement is terminated automatically after 90 minutes.
- 8** Shut off the gas flow to the master meter – marker 17.
- 9** Determine the volume on the unit under test V_P :
- $$V_P = N \times V_{Imp}$$
- N = number of pulses during Δt_P
- V_{Imp} = pulse value V_{Imp} , see page 14 (Technical data)
- 10** Calculate the flow rate on the unit under test:
- $$Q_P = V_P / \Delta t_P$$
- 11** Read off the flow rate on the master meter or calculate if necessary:
- a) taking into account the inherent error of the master meter:
- $$Q_{act,N} = V_N \times 3600 \text{ s/h} / ((1 + F_{N/100}) \times \Delta t_N)$$
- b) If the inherent error of the master meter has already been taken into account in the displayed volume ($V_N = V_{act,N}$):
- $$Q_{act,N} = V_{act,N} \times 3600 \text{ s/h} / \Delta t_N$$

- 12** The accuracy is checked by comparing the flow rates. The pressure and temperature values of the unit under test corrected with reference to the master meter have already been taken into account here:

$$F_P = 100\% \times \left(\frac{(Q_P \times p_P \times T_N) / (Q_{act,N} \times p_N \times T_P) - 1}{1} \right)$$

The following applies:

$$T_P = (273.15 + \{t_g\}) \text{ K}$$

$$p_P = \{p_g\} \text{ mbar}$$

- ▷ The curly brackets mean “numerical value of”.
- ▷ On a nozzle test rig with a known flow rate, steps **4** and **11** can be omitted.
- ▷ The error calculation is based on PTB Testing Instructions, Volume 29: “Messgeräte für Gas – Gaszähler” (Measuring instruments for gas – gas meters), Edition 2003.

RTC test

- ▷ The climatic conditions must be maintained constant at $22 \pm 5^\circ\text{C}$ during the entire test duration. Temperature changes in 24 hours $\leq 2 \text{ K}$.
- ▷ Ensure that conditions remain sufficiently stable during the measurement.
- ▷ The accuracy of the time count can be verified with this test.

- 1** Acclimatize the unit under test and place next to the time reference unit.

- 2** If necessary, activate the time display on both units.

- 3** Ensure synchronous reading by taking a photo.

- 4** Observe a min. testing time of 72 hours.

- 5** Repeat steps **2** and **3**.

- 6** The clock deviation of the unit under test must not exceed the maximum admissible deviation. Maximum admissible deviation = 5 ppm in 24 hours.

Temperature test

- ▷ The accuracy of the temperature measurement can be verified with this test.
- ▷ The temperature test can only be carried out in Service mode.

! CAUTION

To avoid damage to the meter:

- Comply with ambient temperature, see page 14 (Technical data). Deviations from the permitted ambient temperature will be recorded in the error memory.

- ▷ Temperature measurement accuracy, see page 14 (Technical data).

- 1** Install the diaphragm gas meter in a climatic chamber.

- 2** Activate Service mode – see page 5 (Service mode).

- 3** Change to the “Cyclic test” menu.

- ▷ The current gas temperature is displayed.

- 4** Close the climatic chamber.

- 5** Select an ambient temperature as a reference value and bring the climatic chamber to this temperature.

- ▷ To ensure there is also a uniform temperature in the meter, we recommend starting the meter air/gas flow during the temperature adjustment phase.

- ▷ Ensure that temperature distribution remains uniform and stable during the temperature measurement.

- 6** Compare the measured value to the temperature reference value.

- ▷ If required, several reference values can be checked. In this case, repeat the test as of point **5**.

Pressure test

- ▷ The accuracy of the pressure measurement can be verified with this test.

- ▷ The pressure test can only be carried out in Service mode.

! CAUTION

To avoid damage to the meter:

- Comply with the maximum allowable operating pressure, see page 15 (Technical data). Deviations from the permitted operating pressure will be recorded in the error memory.

- ▷ Pressure measurement accuracy, see page 14 (Technical data).

- ▷ Keep the meter a sufficient time under stable conditions to ensure acclimatization.

- ▷ Ensure stable conditions (temperature and pressure) during testing.

- 1** Close off the meter outlet connector so that it is leak-tight, preferably with a valve to permit venting.

- 2** Install a closed system with pressure pump and reference pressure gauge at the inlet.

- 3** Slowly increase the pressure with the pressure pump to the desired pressure.

- 4** Activate Service mode, see page 5 (Service mode).

- 5** Change to the “Pressure” menu.

- ▷ The current pressure inside the meter housing is displayed as absolute pressure.

- 6** Apply at least 5 minutes waiting time to ensure pressure stabilization.



- 7** Compare the measured pressure value to the pressure reference value.

- 8** Slowly open the outlet using the valve to prevent meter damage.

Assistance in the event of malfunction

- ? **Fault**
- ! **Cause**
- **Remedy**

Possible faults and suggested solutions

- ? **The  symbol is displayed.**
- ! If the  symbol appears next to a measured value, this means that the value is invalid.
- After the next time synchronization, the data are recorded again correctly and  disappears.

- ? **When pressing the user keys, the display remains switched off. A beep can nevertheless be heard.**

- ! Energy-saving mode is active. Due to excessive use of the index, the average energy consumption has been exceeded.
- Leave the index unused for an extended period, e.g. 24 hours. After this, the user interface will once again be available.

- ? **When pressing the user keys, the display remains switched off and no beep can be heard.**

- ! The index is defective.
- Contact the manufacturer.

- ? **The  symbol is displayed.**

- ! Low index battery. This symbol is only displayed when index battery power is low.
- Replace the index battery.

- ? **Display light is off.**

- ! Low index battery voltage.
- Replace the index battery.
- ! Display light is defective.
- Contact the manufacturer.

- ▷ In the case of faults which are not described here, contact the manufacturer immediately.

Accessories

External antenna

Only the following antennas are approved as external antennas.

Elster Part Nos.:

72910264, "Retrofit kit external antenna EI3 / 2.5m" composed of:

- service cover -cpl. EA EI3 (32320088)
- PT screw K40x16 (03017232)
- GSM antenna L=2.5m (04271001)

72910265, "Retrofit kit external antenna EI3 / 5m" composed of:

- service cover -cpl. EA EI3 (32320088)
- PT screw K40x16 (03017232)
- GSM antenna L=5m (04271002)

Spare parts

Only the following spare parts are approved:

Communication module

Use only original Elster communication modules.

Elster Part No.:

72910267, "spare parts kit communication module EI3" composed of:

- communication module GSM EI3 (32320046)
- PT screw K40x16 (03017232)
- screw locking cap EI (32447510)

Battery for the communication module

Use only original Elster batteries.

Elster Part No.:

72910266, "spare parts kit batterypack C.M. GSM EI3" composed of:

- batterypack comm.module GSM EI3 (32447571)
- PT screw K40x16 (03017232)
- screw locking cap EI (32447510)

Screw locking cap

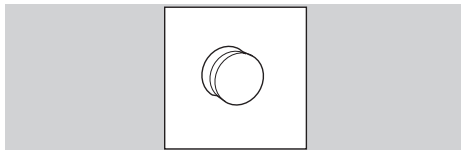

Part No.: 32447510.

Technical data

RoHS compliant

Application with diaphragm gas meters BK..B

Enclosure: IP 65.

Maximum allowable operating pressure p_{max} (as

overpressure): see index plate,

base gas pressure p_g ; see index plate,

operating pressure range (absolute) p_g :

800 to 1600 mbar.

Life of battery for index: approx. 15 years.

Life of battery for communication module:

approx. 5 years.

Ambient temperature of index: -25 to +55°C (for entire meter, see index plate).

Accuracy of the clock: 0.4 s/day at 20°C on the day of manufacture.

Temperature measurement accuracy on the day of manufacture:

± 0.2°C in the range from -10 to +55°C.

± 0.25°C in the range from -25 to -10°C.

Pressure measurement accuracy: ± 5 mbar on the day of manufacture.

Pulse value V_{Imp} for pulse tests via optical interface:

Gas meter	Decimal place in display	Pulse value V_{Imp} in dm^3
BK-G6	3	1
BK-G10–BK-G40	2	10

Communication module: GSM RF technology.

Data logger for past meter readings:

up to 20 weeks in hourly intervals.

Optical interface: pursuant to EN 62056-21, Mode (E), Annex B.2.

Pulse output

Type of switch: open collector transistor, normally closed.

For switching voltage and current, see section “ATEX explosion protection” below.

Resolution: 1 pulse per 10 litres of base volume.

Maximum pulse frequency: 4 Hz.

Minimum pulse duration: 125 ms.

For further technical data on diaphragm gas meters BK, see:

“Operating instructions for diaphragm gas meters BK-G1.6 to BK-G25” →

http://docuthek.kromschroeder.com/doclib/main.php?language=1&folderid=400041&by_class=2&by_lang=-1

“Instruction Manual, Industrial Diaphragm Gas Meters Type BK-G40 · BK-G65 · BK-G100 and Type BK-G40T · BK-G65T · BK-G100T” →

http://docuthek.kromschroeder.com/doclib/main.php?language=1&folderid=400045&by_class=2&by_lang=-1

ATEX explosion protection

The index EI3 is certified as an ATEX subassembly and is marked as follows:

 II 2 G Ex ib IIA T4 Gb

 = Specific explosion protection mark

II = Equipment group for “non-mining”

2G = Equipment category 2 (zone 1) for gas

EX = Symbol for electrical equipment built according to European standards

ib = Type of ignition protection:

i = intrinsically safe

b = suitable for use in zone 1

IIA = Explosion group for gases

T4 = Temperature class: maximum allowable surface temperature: 135°C

Gb = Equipment protection level (zone 1)

The batteries and communication modules are certified as parts of the electronic index. Use only spare parts from Elster. For suitable batteries and communication modules, see page 14 (Spare parts).

The electrical interfaces feature the following parameters:

Pulse output:

– U_i = 26.6 V

– I_i = 250 mA

– P_i = 414 mW

– C_i = 0.012 μ F

– L_i = 0 mH

For further technical data on diaphragm gas meters BK, see:

“Operating instructions for diaphragm gas meters BK-G1.6 to BK-G25” → http://docuthek.kromschroeder.com/doclib/main.php?language=1&folderid=400041&by_class=2&by_lang=-1

“Instruction Manual, Industrial Diaphragm Gas Meters Type BK-G40 · BK-G65 · BK-G100 and Type BK-G40T · BK-G65T · BK-G100T” → http://docuthek.kromschroeder.com/doclib/main.php?language=1&folderid=400045&by_class=2&by_lang=-1

Logistics

Transport

Diaphragm gas meters are always to be transported in the upright position. On receipt of the product, check that the delivery is complete, see page 2 (Part designations). Report any transport damage immediately.

Storage

Diaphragm gas meters are always to be stored in the upright position and in a dry place. Ambient temperature: see page 14 (Technical data).

Disposal

Meters with electronic components:

Components, particularly batteries, are to be disposed of separately.

On request, old units may be returned carriage paid to the manufacturer, see page 16 (Contact), in accordance with the relevant waste legislation requirements.

Contact

Honeywell

Germany

Elster GmbH
Strotheweg 1
49504 Lotte
Tel. +49 541 1214-0
Fax +49 541 1214-370
info@elster-instromet.com
www.elster-instromet.com

United Kingdom

Elster Metering Limited
Paton Drive
Tollgate Business Park
Beaconside
Stafford, ST16 3EF
Tel. +44 1785 275200
Fax +44 1785 275305
jeavons.info@gb.elster.com
www.elstermetering.co.uk

Ireland

Active Energy Control Ltd.
Unit 4, Clare Marts
Quin Road
Ennis, Co. Clare
Tel. +353 65 6840600
Fax +353 65 6840610
info@aec.ie
www.aec.ie