



**Operating instructions**  
**Diaphragm gas meters**  
**BK-G1.6 to BK-G25**

**Contents**

**Diaphragm gas meters**  
**BK-G1.6 to BK-G25** ..... 1  
**Contents** ..... 1  
**Safety** ..... 1  
**Checking the usage** ..... 2  
 Diaphragm gas meters BK-G1.6 to G25 ..... 2  
 BK with integrated "Smart Valve" ..... 2  
 Type code ..... 2  
 Part designations ..... 2  
 Type label/Index plate ..... 2  
 ATEX identification ..... 3  
**Installation** ..... 4  
**Temperature test point** ..... 5  
**Pressure test point on housing (optional)** ... 6  
 Connecting the piping ..... 6  
**Pressure test point on outlet connector**  
**(optional)** ..... 6  
 Opening the test nipple ..... 6  
 Closing the test nipple ..... 6  
**Tightness test** ..... 6  
**Commissioning** ..... 7  
**Maintenance/Removal** ..... 8  
**Accessories** ..... 8  
**Technical data** ..... 9  
**Declarations of conformity** ..... 10  
 ATEX legend ..... 14  
**Logistics** ..... 14  
**Contact** ..... 14

**Safety**

**Please read and keep in a safe place**



Please read through these instructions carefully before installing or operating. Following the installation, pass the instructions on to the operator. This unit must be installed and commissioned in accordance with the regulations and standards in force. These instructions can also be found at [www.docuthek.com](http://www.docuthek.com).

**Explanation of symbols**

- , **1**, **2**, **3**... = Action
- > = Instruction

**Liability**

We will not be held liable for damage resulting from non-observance of the instructions and non-compliant use.

**Safety instructions**

Information that is relevant for safety is indicated in the instructions as follows:

**⚠ DANGER**  
 Indicates potentially fatal situations.

**⚠ WARNING**  
 Indicates possible danger to life and limb.

**! CAUTION**  
 Indicates possible material damage.

All interventions may only be carried out by qualified gas technicians. Electrical interventions may only be carried out by qualified electricians.

**Conversion, spare parts**

All technical changes are prohibited. Only use OEM spare parts.

**Changes to edition 07.19**

- The following chapters have been changed:
- Checking the usage
  - Declarations of conformity

## Checking the usage

### Diaphragm gas meters BK-G1.6 to G25

Residential or commercial diaphragm gas meters BK for recording gas consumption values for natural gas, town gas, propane and butane, as gases of the first to third families pursuant to DIN EN 437:2003 (DVGW Code of Practice G260). If used for internal measurements which are not subject to statutory testing, the gas meter is also suitable for hydrogen, nitrogen, air and inert gases.

The meters are designed for use in air at normal atmospheric conditions. For use in other environments, please contact the manufacturer (see also page 4 (Installation)).

### BK with integrated "Smart Valve"

Not suitable for highly contaminated gases, e.g. town gas.

### Potentially explosive atmosphere

Diaphragm gas meters that are labelled with  $\text{CE}$  and  $\text{Ex}$  (see sticker near the index) are suitable for operation in potentially explosive atmospheres, see page 10 (Declarations of conformity).

The meter function is only guaranteed when used under the specified operating conditions – see page 9 (Technical data). Any other use is considered as non-compliant.

### Type code

Code	Description
<b>BK-G</b>	Diaphragm gas meter
	Flow rate
<b>1.6</b>	0.016–2.5 m <sup>3</sup> /h
<b>2.5</b>	0.025–4 m <sup>3</sup> /h
<b>4</b>	0.04–6 m <sup>3</sup> /h
<b>6</b>	0.06–10 m <sup>3</sup> /h
<b>10</b>	0.1–16 m <sup>3</sup> /h
<b>16</b>	0.16–25 m <sup>3</sup> /h
<b>25</b>	0.25–40 m <sup>3</sup> /h
<b>M</b>	Mechanical index
<b>C</b>	Chekker mechanical index
<b>A</b>	Absolute ENCODER index
<b>E</b>	Electronic index
<b>B</b>	Indication of volume at base conditions
	Temperature conversion:
<b>T</b>	mechanical
<b>Te</b>	electronic
<b>TB</b>	mechanical-electronic temperature conversion and pressure correction
<b>TeB</b>	electronic temperature conversion and pressure correction

## Part designations

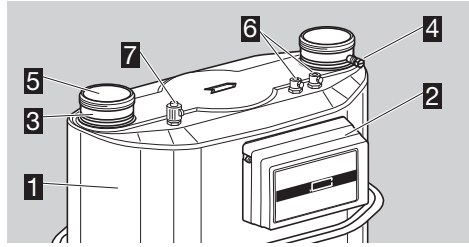

- 1** Diaphragm gas meter BK
- 2** Index with index plate
- 3** Connectors
- 4** Pressure test point to BS4161 (optional)
- 5** Protective caps
- 6** 2 x thermowells (optional)
- 7** Pressure test point with sealing sleeve (optional)

### Type label/Index plate

Please quote for all enquiries:

- ▷ The manufacturer's serial number **S/N** can be found at the bottom of the type label.
- ▷ The customer identification number is under the barcode.
- ▷ Indicated volume:
  - V: volume at metering conditions
  - V<sub>tb</sub>: converted volume to base temperature t<sub>b</sub>
  - V<sub>b</sub>: converted volume to base conditions (pressure and temperature)

### BK-G..M..

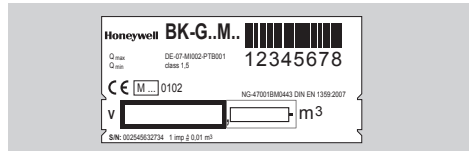

### BK-G..A.. with Absolute ENCODER index

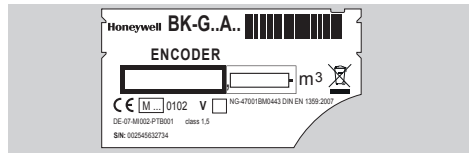

### BK-G..E with index EI4

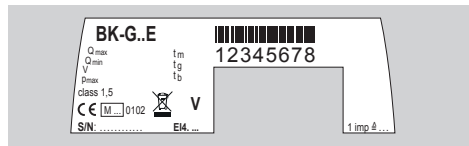

### BK-G..B with index EI3

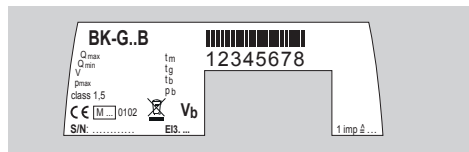

## BK-G..E with index EI5.00, EI5.12

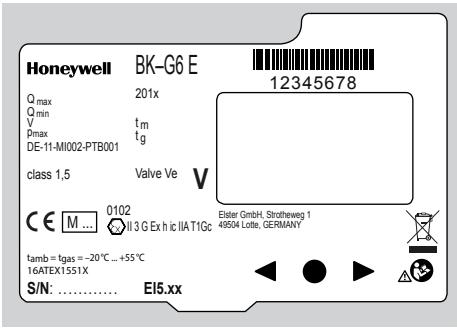

## BK-G..E with index EI5.01

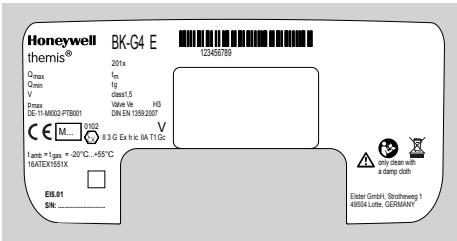

## BK-G..Ete with index EI6

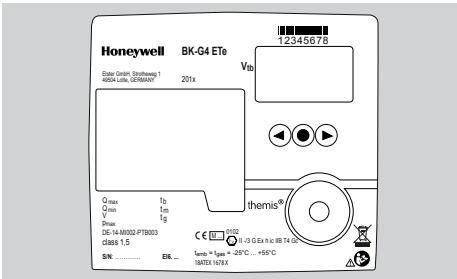

## BK-G..E.. and BK-G..B

The following data is not necessarily specified on the type label/index plate, but can be called up in the menu:

- specified centre temperature  $t_{sp}$  (for meters with temperature conversion only),
  - EN 1359 registration number (if available),
  - firmware version.
- ▷ A number of variants are available for the electronic indexes. The Elx.xx ID of the index variant can be found at the bottom of the type label or on the index cover next to the serial number S/N.



Further information can be found in the supplementary operating instructions of the relevant index.

## Diaphragm gas meters with integrated valve



Valve variants:

Ve = bi-stable valve with electronic flow rate testing (with electronic index EI)

## ATEX identification

### BK-G..M, BK-G..C, BK-G..MT, BK-G..CT



Use as follows:

Category, internal: none, external: 2 (Zone 1).

Type of atmosphere: gases, hazes and vapours.

### BK-G..M, BK-G..C, BK-G..MT, BK-G..CT with RFID passive tag



Use as follows:

Category, internal: none, external: 2 (Zone 1).

Type of atmosphere: gases, hazes and vapours.

### BK-G..B



Use as follows:

Category, internal: none, external: 2 (Zone 1).

Type of atmosphere: gases, hazes and vapours.

## BK-G..E with EI5.00, EI5.01



0102

II 3 G Ex h ic IIA T1Gc 4E

$t_{amb} = t_{gas} = -20^{\circ}\text{C} \dots +55^{\circ}\text{C}$   
16ATEX1551X

S/N: ..... EI5.0x

Use as follows:

Category: 3 (Zone 2).

Type of atmosphere: gases, hazes and vapours.

## BK-G..E with EI5.12



0102

II 3 G Ex h ic IIA T1Gc

$t_{amb} = t_{gas} = -20^{\circ}\text{C} \dots +55^{\circ}\text{C}$   
19ATEX1743X

S/N: ..... EI5.12

Use as follows:

Category: 3 (Zone 2).

Type of atmosphere: gases, hazes and vapours.

## BK-G..ETe with EI6

t b  
t m  
t g  
IP  
Valve Ve

themis®  
GPRS

0102  
II -/3 G Ex h ic IIB T4 Gc

EI6.0x  $t_{amb} = t_{gas} = -25^{\circ}\text{C} \dots +55^{\circ}\text{C}$   
18ATEX1678 X

Use as follows:

Category, internal: none, external: 3 (Zone 2).

Type of atmosphere: gases, hazes and vapours.

## Installation

### ⚠ WARNING

Please observe the following to ensure that neither persons nor the gas meter are damaged during installation and operation:

- Note the max. allowable operating pressure  $p_{max}$  and measuring range  $Q_{max}$ , see page 2 (Type label/Index plate).
- Note the permitted ambient temperature  $t_m$  and gas temperature  $t_g$ , see page 2 (Type label/Index plate) or page 9 (Technical data).
- The gas meters are certified for mechanical environments pursuant to Class M1 of Directive 2014/32/EU. When installed, the meters must not be subject to permanent vibration such as that caused by machines in the vicinity. In case of doubt, vibration isolation must be provided. For gas meter versions BK..A, BK..E and BK..B, Class E2 for electromagnetic environments also applies.
- The dangers of chemical reactions between gas meter parts and the chemical substances in the environment are to be discussed by the manufacturer and the operator and must be eliminated.
- When installing the diaphragm gas meter BK with integrated valve, make sure that no dirt particles get into the meter and thus into the valve.
- The yellow sealing sleeve protects the pressure test point on the gas meter. It may only be opened for connecting a pressure measuring line.
- Use seals made from tested materials. Elastomer seals or asbestos-free flat seals from Elster are recommended.
- Only use the seals once.
- For meters resistant to high temperatures, only use seals tested to be resistant to high temperatures.
- For installation and operation, note the applicable national regulations and the directives of the gas supply company. For Germany, the valid DVGW Code of Practice G600 (DVGW-TRGI) applies.
- Work on meters and the installation of meters which are marked with and are installed in potentially explosive atmospheres may only be carried out by persons with appropriate qualifications.
- The gas meter marked with must be included in the equipotential bond when being installed in a potentially explosive atmosphere, e.g. by connecting it to a grounded pipeline. Installation must be carried out in accordance with EN 60079-14.

- The gas meter marked with  must be protected from falling parts.
- Avoid subjecting the unit to mechanical stress and prevent damage. Gas meters must be installed without any mechanical stress, preferably only by suspending them on the connectors. When using additional clamps, it must be ensured that no lateral forces act on the gas meter. These can be avoided by using flexible or supple connection lines, for instance.

- ▷ If the calibration seal has been damaged or removed, the gas meter is no longer approved for measurements which are subject to statutory testing.
- ▷ If the gas meter is stored or installed outdoors, protect the site against rain. Condensing humidity is permitted.
- ▷ Meters which are marked with H3 are suitable for installation outdoors without additional protection.

**1** Remove protective caps.

- ▷ Installation in the vertical position: connectors must be pointing upwards.
- ▷ Note direction of flow (arrow).
- ▷ The gas meter must not be in contact with masonry or other parts.
- ▷ Ensure that there is sufficient installation space.
- ▷ Ensure unobstructed view of the index.
- ▷ The seal faces on the screw unions must be clean and damage-free.
- ▷ Ensure that the seal is correctly seated.

Co-axial meters:

- ▷ The seal must be centred over the internal diameter.

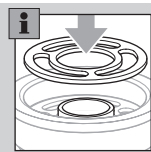

- ▷ When using an elastomer seal, always use a pressure ring (shape A).
- ▷ Note the installation position of the pressure ring. The inner beaded edge must point upwards.

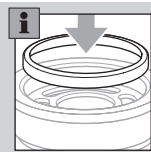

- ▷ Replace damaged pressure rings when replacing the meter.

Co-axial and two-pipe meters:

- ▷ For the compression of seals and the resulting tightening torques for the screw unions, the seal manufacturers' specifications must be observed. Tightening torques for the recommended flat seals in conjunction with screw connectors pursuant to DIN 3376-1 and 3376-2, see [www.docuthek.com](http://www.docuthek.com) → Elster-Instromet → Products → Gas measuring devices → Diaphragm meters → Ergänzung für Betriebsanleitung BK, Verschraubungen und Anzugsmomente für BK-G1,6 bis BK-G25 (Supplement to BK operating instructions, Screw unions and tightening torques for BK-G1.6 to BK-G25) (D).

**2** Install the gas meter free of mechanical stress.

- ▷ If a pulse transmitter IN-Z6x is used for pulse tapping on the gas meter marked with  – see Data sheet for pulse transmitter IN-Z6x (D, GB) → [www.docuthek.com](http://www.docuthek.com) → Elster-Instromet → Products → Gas measuring devices → Diaphragm meters → Pulse transmitter IN-Z61 and the standard EN 60079-14 (Explosive atmospheres).

**Temperature test point**

- ▷ Temperature sensors can be inserted into the thermowells for measuring the gas temperature in the meter housing.

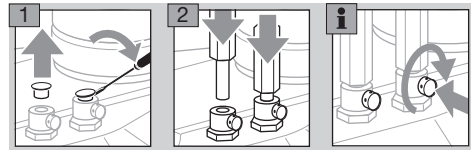

- 3** Secure each of the temperature sensors using the capstan screw provided.

## Pressure test point on housing (optional)

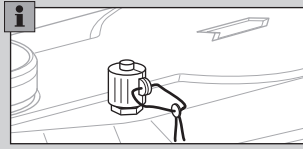

### Connecting the piping

#### **⚠ WARNING**

In order to ensure that the gas meter is tight:

- The pressure test nipple must not be twisted, bent, or otherwise manipulated.
  - When installing, always secure the pressure test nipple using a suitable spanner.
- ▷ Functional safety and reliability are ensured only if the material combination of the screw connector and the pressure line are inter-matched.
  - ▷ Only use the olive and the attached union nut supplied. The olive is secured to the sealing sleeve.
  - ▷ When re-ordering, use original Parker EO progressive ring fittings PSR/DPR.

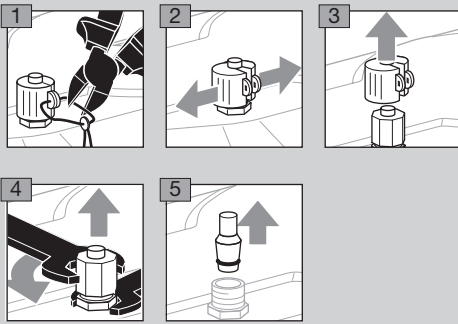

- ▷ Use corrosion-resistant, seamless precision steel tube pursuant to DIN EN 10305-4 (external diameter 6 mm, material E235 = 1.0308). For other materials, use a suitable adapter and note the Parker/EO recommendations.
- ▷ Install pipes free of mechanical stress.

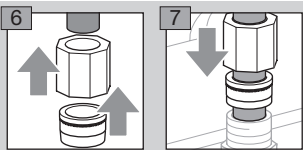

- 8** Screw on the union nut by hand as far as it will go.
- ▷ At the same time, press the end of the pipe firmly against the stop.
- 9** Mark the position of the union nut and tighten with about 1½ turns.

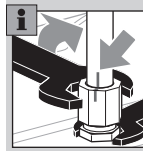

- ▷ When reinstalling, the union nut will be turned to the original position and then further tightened through approx. 30°.
- 10** Once the installation and tightness test are complete, see page 6 (Tightness test), protect the pressure test point against external access with the sealing sleeve and the seal.

## Pressure test point on outlet connector (optional)

BS4161-compliant pressure test nipple

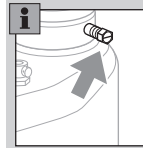

- ▷ Use a 10 mm spanner to release/tighten the test point screw.
- ▷ The test nipple is secured to prevent it turning with the screw.

### Opening the test nipple

- 1** Remove the screw from the test nipple completely.
- ▷ The gas connection is open.

### Closing the test nipple

- 1** Insert the screw by hand as far as possible.
- 2** Tighten the screw with a torque of 3 Nm + 0.5 Nm.
- 3** Check for tightness, see page 6 (Tightness test).

#### **⚠ WARNING**

If the test nipple has unexpectedly come loose, the gas meter must be regarded as damaged and must be replaced.

## Tightness test

- ▷ Check the pipework for leaks prior to installation of the gas meter, in case the pipework is tested with a greater test pressure than the max. allowable operating pressure  $p_{max}$  for the gas meter. Otherwise, the installed gas meter may be damaged.
- ▷ If a valve is integrated in the diaphragm gas meter BK, see page 3 (Diaphragm gas meters with integrated valve), this must be opened for the tightness test.
- ▷ Ensure the customer's consumers are closed.
- 1** Apply the test pressure slowly to the gas meter.

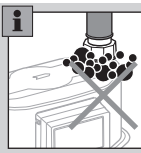
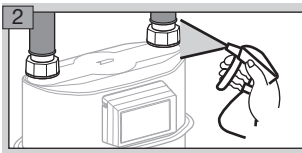

- ▷ If a pressure measuring line has been retrofitted to the diaphragm gas meter, check this connection for tightness.

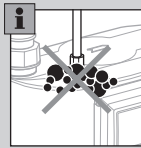
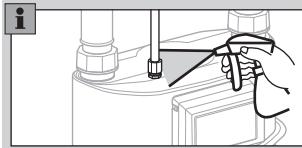

- ▷ If the BS4161-compliant test nipple on the meter has been opened and then closed again, check this connection for tightness.

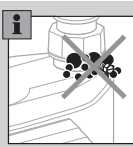

- 3 After the tightness test, slowly vent the gas meter.
- 4 If a pressure measuring line has been retrofitted to the diaphragm gas meter, protect the pressure test point against external access with a sealing sleeve and a seal.

## Commissioning

Once the tightness test has been successfully completed, the gas meter is ready for operation.

- ▷ Slowly open the manual valve.

### Interfaces

Diaphragm gas meters BK are equipped with different interfaces, depending on the index version. Only original Elster spare parts may be used in the following cases:

- if devices are marked with ,
- if metrological data subject to statutory control is transferred via the interface.
- ▷ For statutory, metrological use, add-on components must be sealed. Permitted accessories, see page 8 (Accessories).

### BK-G..M with mechanical index

For pulse tapping, the pulse transmitter IN-Z6x can be connected. For further information regarding usage and the interface –see Data sheet for pulse transmitter IN-Z6x → [www.docuthek.com](http://www.docuthek.com) → Elster-Instromet → Products → Gas measuring devices → Diaphragm meters → Pulse transmitter IN-Z61.

## ⚠ WARNING

The following safety instructions apply for meters which are marked with  and fitted with a pulse transmitter IN-Z6x:

- Only for connection to intrinsically safe electrical circuits, see page 9 (Technical data).
- If the intrinsically safe electrical circuit is grounded from a technical-safety point of view, the intrinsically safe equipotential bond must cover the entire area of installation.
- EN 60079-14 is to be noted when installing pulse transmitters.
- The intrinsically safe electrical circuits of pulse transmitters IN-Z61 and IN-Z64 are considered to be grounded at voltages > 10 V, if the plug connector housings are connected to the ground potential.
- The intrinsically safe electrical circuits of pulse transmitters IN-Z61, IN-Z62 and IN-Z65 are to be considered as non-grounded.

### BK-G..A with Absolute ENCODER AE3, AE5 and communication module ACM

If the diaphragm gas meter BK-G..A is fitted with communication module ACM, you can find further information ...

- for commissioning in the Communication module ACM M-BUS WIRE or ACM SCR+WIRE... operating instructions (D/GB/SK/NL) → [www.docuthek.com](http://www.docuthek.com) → Elster-Instromet → Products → Smart metering → ACM: communication modules.
- on the protocols in the corresponding documents at [www.docuthek.com](http://www.docuthek.com) → Elster-Instromet → Products → Smart metering → AE: protocol variants.

### BK-G..E, BK-G..ETe(B), BK-G..B with electronic index

For further commissioning of diaphragm gas meters with electronic index –see the operating instructions of the respective electronic indexes → [www.docuthek.com](http://www.docuthek.com) → Elster-Instromet → Products → Smart metering → Electronic index.

### BK-G... with RFID passive tag

## ⚠ WARNING

On meters which are marked with  and fitted with an RFID passive tag, the transmission capacity of the RFID reader must not exceed the maximum limits set out in EN 60079-0.

## Diaphragm gas meters BK with integrated valve

In the event that the diaphragm gas meter BK is fitted with an integrated valve, see page 3 (Diaphragm gas meters with integrated valve) for designation, the gas supply can be connected or disconnected remotely.

Unless otherwise agreed, the valve is open on delivery as standard.

### WARNING

- The grid operator is responsible for the safe remote shut-down and restart of the diaphragm gas meter.
  - The integrated valve does not assume the functions of a safety shut-off valve.
- ▷ Should the diaphragm gas meter BK be ordered with a valve, but without control electronics to be complemented by a third party, the technical data of the control interface is to be requested from Elster GmbH and observed.
- ▷ The manufacturer of the control electronics is responsible for creating the conditions required for safe operation of the valve. Instructions on commissioning and operation are to be taken from the operating instructions for the control electronics.

### ... with valve variant Ve

- ▷ Notes on the function can be found in the operating instructions of the electronic index. Technical data, see page 9 (Technical data).

## Maintenance/Removal

Gas meters BK-G1.6 to 25 from Elster are maintenance-free (constraints for BK-G...E... and BK-G...B).

- ▷ When used for custody transfer measurements, recalibration must be carried out in accordance with national directives.
- ▷ If the screw unions are loosened for maintenance work or retesting, replace the seals.
- ▷ After the gas meter has been removed, immediately close the connectors with protective caps in order to prevent ingress of dirt particles.
- ▷ For meters with electronic indexes (BK-G...E... and BK-G...B), it may be necessary to change the battery, see "Operating instructions for operators and installers" for the corresponding electronic index.

### WARNING

A certain amount of gas may remain in the gas meter. Taking into consideration the risk of explosion, it is important to adopt safety measures, e.g.:

- Following removal of the gas meter, purge it thoroughly with inert gas.
- For transporting the gas meter with gas residue, use a vehicle with an open or a ventilated loading area.
- The indexes must not be opened in an explosion-hazard area even for maintenance and repair. For opening the service cover on the electronic index, e.g. to change the battery, see "Operating instructions for operators and installers" for the corresponding electronic index.
- Meters which are installed in a potentially explosive atmosphere may only be cleaned using a damp cloth to avoid static electricity charge.

## Accessories

We recommend using Elster GmbH accessories only.

### Pulse transmitters of the IN-Z6x series

- ▷ Also for devices which are marked with 

**IN-Z61** (Part No. 32319615)

Retrofit kit with connection cable –

Order No. 72910109

Retrofit kit without connection cable –

Order No. 72910114

**IN-Z62** (Part No. 32319616)

Shipping unit – Order No. 32447303

**IN-Z63** (Part No. 32319617)

Retrofit kit – Order No. 72910110

Retrofit kit with cable socket – Order No. 72910112

**IN-Z64** (Part No. 32319618)

Retrofit kit – Order No. 72910117

**IN-Z65** (Part No. 32319762)

Retrofit kit – Order No. 72910180

**IN-Z68** Part/Order No. 32320278

Interface parameters, see page 9 (Technical data).

- ▷ As regards explosion protection, pulse transmitters IN-Z6x are classified as simple electrical apparatus and must thus not be marked.

### Communication modules ACM for AE3 to AE5

For AE3:

- ACM M-Bus WIRE (Order No. 32906432)
- ACM SCR+ WIRE (Order No. 32906465)
- ACM IZAR RADIO COMPAKT I-Key (Order No. 04406012)

For AE3 and AE5:

- ACM 5.1 ECO Wire (Order No. 32320346)
- ACM 5.2 M-Bus Wire (Order No. 32320347)
- ACM 5.5 SCR Wire (Order No. 32320348)



## Communication modules for meters with explosion protection

Meters which are marked with  may only be retrofitted with communication modules certified in accordance with 2014/34/EU and which correspond to the appropriate interface parameters (see page 9 (Technical data)).

## Technical data

### Diaphragm gas meter BK

Gas type: natural gas, town gas, propane and butane, as gases of the first to third families pursuant to DIN EN 437:2003 (DVGW Code of Practice G260). The following technical data can be found on the type label/index plate:

- max. allowable operating pressure  $p_{\max}$
- measuring range:  $Q_{\min}/Q_{\max}$
- max. allowable ambient temperature range  $t_m$
- max. allowable gas temperature range  $t_g^*$
- cyclic volume  $V$

For meters with temperature conversion only:

- base gas temperature  $t_b$
- specified centre temperature  $t_{sp}^{**}$

Only for diaphragm gas meters BK...ETeB:

- base pressure  $p_b$
- assumed (inlet) pressure  $p_{sp}$

Other technical data:

- transitional flow rate  $Q_t = 0.1 \times Q_{\max}$
- max. allowable storage temperature range: -25 to +60°C
- mechanical environment class: M1
- ▷ Observe installation conditions! See 4 (Installation).
- electromagnetic environment class: E2

Supplementary notes:

\* If operated within the gas temperature range, the measurement error still lies within the required error limits. If no gas temperature  $t_g$  is specified on the index plate, the following applies:  $t_g = t_m$ .

\*\* The specified centre temperature  $t_{sp}$  of the BK-G...E... series and BK-G...B meters is not stated on the index plate, but can be called up in the display using the menu.

## Diaphragm gas meters BK with pressure test point

Pressure test point: 24° olive fitting to EN ISO 8434-1, L6 x M12 x 1.5-St.

## Diaphragm gas meters BK with explosion protection

For meters of Category 1 which are marked with , the ambient temperature  $t_{amb}$  and the gas temperature  $t_{gas}$  are limited to a maximum range between -20°C and +55°C. In this case, the admissible temperatures are to be taken from the ATEX identification sticker.

The following parameters apply for meters BK-G..M, BK-G..C, BK-G..MT, BK-G..CT with pulse transmitter IN-Z6x:

### IN-Z61, IN-Z62, IN-Z63, IN-Z64, IN-Z65:

$U_i = 30\text{ V}$   
 $I_i = 50\text{ mA}$   
 $P_i = 250\text{ mW}$   
 $C_i, L_i$  negligible

### IN-Z68:

$U_i = 8\text{ V}$   
 $I_i = 10\text{ mA}$

## Diaphragm gas meters BK with integrated valve Ve

Opening time incl. flow rate measurement: < 2 min.  
Opening and closing times: approx. 5 s (max. 15 s).

Max. operating pressure for valve operation: 100 mbar.

▷ The operating pressure of the gas meter can be higher if necessary.

Leakage flow (closed): max. 1 l/h up to 100 mbar.





## EU - Konformitätserklärung

EU Declaration of Conformity

<b>Produkt</b> Product	Gaszähler / Gaszähler mit eingebauter Temperaturumwertung Gas meter / Gas meter with integrated temperature conversion		
<b>Typ, Ausführung</b> Type, model	BK-G1,6 M – BK-G25 M BK-G1,6 MT – BK-G25 MT	BK-G1,6 C – BK-G25 C BK-G1,6 CT – BK-G25 CT	
<b>Produkt-Kennzeichnung</b> Product marking	M... 0102  II -/2 G c IIB TX <b>DE-07-MI002-PTB001 / DE-07-MI002-PTB002</b>		
<b>EU-Richtlinien</b> EU Directives	2014/32/EU – MID	2014/34/EU – ATEX	2011/65/EU – RoHS (mit / with IN-Z6...)
<b>Normen</b> Standards	DIN EN 1359:2007 (EN 1359:1998 + A1:2006)	EN ISO 80079-36:2016 EN ISO 80079-37:2016	
<b>EU-Baumusterprüfung</b> EU-type examination	DE-07-MI002-PTB001, Rev.11 / DE-07-MI002-PTB002, Rev.11 (MID - 2014/32/EU Anhang II Modul B / Annex II module B) Physikalisch-Technische Bundesanstalt (PTB) (National Metrological Institute) Notifizierte Stelle / Notified Body 0102		
<b>Prüfungen</b> Tests		Konformitätsaussage TÜV Nord Statement of conformity TÜV Nord TÜV 11 ATEX 090370 X	
<b>Überwachungsverfahren</b> Surveillance procedures	2014/32/EU Anhang II, Modul D / 2014/32/EU Annex II, module D Physikalisch-Technische Bundesanstalt (PTB) (National Metrological Institute) Notifizierte Stelle / Notified Body 0102 Zertifikat / certificate: DE-M-AQ-PTB025		
<b>Konformitätsbewertungsverfahren</b> Conformity assessment procedure		2014/34/EU Anhang VIII, Modul A 2014/34/EU Annex VIII, module A	

### Wir erklären als Hersteller:

Die entsprechend gekennzeichneten Produkte erfüllen die Anforderungen der aufgeführten Richtlinien und Normen. Sie stimmen mit dem geprüften Baumuster überein. Die Herstellung unterliegt dem genannten Überwachungsverfahren.

### In our capacity as manufacturer, we hereby declare:

Products labelled accordingly meet the requirements of the listed directives and standards. They correspond to the tested type sample. The production is subject to the stated surveillance procedure.

Unterzeichnet für und im Namen der Elster GmbH – Signed for and on behalf of Elster GmbH

Lotte / Stará Turá, 2019-10-14

DocuSigned by:  
  
 8BDDA250719249E

**Ulrich Clasemann**  
Geschäftsführer Standort Lotte  
Managing Director, Lotte site

DocuSigned by:  
  
 6F8D19E7C8A5A2

**Guido Temme**  
Leiter Entwicklung Gasmessung  
Director R&D Gas Metering

DocuSigned by:  
  
 F4C30115E40D45B

**Peter Bernhauser**  
Betriebsleiter Standort Stará Turá  
Plant Director, Stará Turá site

**Elster GmbH, Strothweg 1, 49504 Lotte, DEUTSCHLAND / GERMANY**



**EU-Konformitätserklärung**  
EU Declaration of Conformity

<b>Produkt</b> Product	Gaszähler / Gaszähler mit eingebauter Temperaturumwertung Gas meter / Gas meter with integrated temperature conversion		
<b>Typ, Ausführung</b> Type, model	BK-G1,6 M – BK-G25 M    BK-G1,6 C – BK-G25 C BK-G1,6 MT – BK-G25 MT    BK-G1,6 CT – BK-G25 CT (mit RFID-Passiv-Transponder / with RFID passive tag)		
<b>Produkt-Kennzeichnung</b> Product marking	 <b>DE-07-MI002-PTB001 / DE-07-MI002-PTB002</b>		
<b>EU-Richtlinien</b> EU Directives	2014/32/EU – MID	2014/34/EU – ATEX	2011/65/EU – RoHS
<b>Normen</b> Standards	DIN EN 1359:2007    EN ISO 80079-36:2016 (EN 1359:1998 + A1:2006)    EN ISO 80079-37:2016 EN 60079-0:2012 +A11:2013 EN 60079-11:2012		
<b>EU-Baumusterprüfung</b> EU-type examination	DE-07-MI002-PTB001, Rev.11 / DE-07-MI002-PTB002, Rev.11 (MID - 2014/32/EU Anhang II Modul B / Annex II module B) Physikalisch-Technische Bundesanstalt (PTB) (National Metrological Institute) Notifizierte Stelle / Notified Body 0102		
<b>Prüfungen</b> Tests	Elster Prüfbericht Elster test report 17 ATEX 1673 X		
<b>Überwachungsverfahren</b> Surveillance procedures	2014/32/EU Anhang II, Modul D / 2014/32/EU Annex II, module D Physikalisch-Technische Bundesanstalt (PTB) (National Metrological Institute) Notifizierte Stelle / Notified Body 0102 Zertifikat / certificate: DE-M-AQ-PTB025		
<b>Konformitätsbewertungsverfahren</b> Conformity assessment procedure	2014/34/EU Anhang VIII, Modul A 2014/34/EU Annex VIII, module A		

**Wir erklären als Hersteller:**

Die entsprechend gekennzeichneten Produkte erfüllen die Anforderungen der aufgeführten Richtlinien und Normen. Sie stimmen mit dem geprüften Baumuster überein. Die Herstellung unterliegt dem genannten Überwachungsverfahren.

**In our capacity as manufacturer, we hereby declare:**

Products labelled accordingly meet the requirements of the listed directives and standards. They correspond to the tested type sample. The production is subject to the stated surveillance procedure.

Unterzeichnet für und im Namen der Elster GmbH – Signed for and on behalf of Elster GmbH

Lotte / Stará Turá, 2019-10-14

DocuSigned by:  
  
 BFB18B7C8A842  
**Guido Temme**  
 Leiter Entwicklung Gasmessung  
 Director R&D Gas Metering

DocuSigned by:  
  
 8B2CA29719248E  
**Ulrich Clasemann**  
 Geschäftsführer Standort Lotte  
 Managing Director, Lotte site

DocuSigned by:  
  
 F4C815EAD428B  
**Peter Bernhauser**  
 Betriebsleiter Standort Stará Turá  
 Plant Director, Stará Turá site

**Elster GmbH, Strothweg 1, 49504 Lotte, DEUTSCHLAND / GERMANY**



## EU-Konformitätserklärung

### EU Declaration of Conformity

<b>Produkt</b> <i>Product</i>	Gaszähler (mit Absolut-ENCODER) <i>Gas meter (with Absolute ENCODER)</i> Gaszähler mit eingebauter Temperaturumwertung (mit Absolut-ENCODER) <i>Gas meter with integrated temperature conversion (with Absolute ENCODER)</i>		
<b>Typ, Ausführung</b> <i>Type, model</i>	BK-G1,6 A – BK-G25 A BK-G1,6 AT – BK-G25 AT		
<b>Produkt-Kennzeichnung</b> <i>Product marking</i>	M... 0102 <b>DE-07-MI002-PTB001 / DE-07-MI002-PTB002</b>		
<b>EU-Richtlinien</b> <i>EU Directives</i>	2014/32/EU – MID	2014/30/EU – EMC	2011/65/EU – RoHS
<b>Normen</b> <i>Standards</i>	DIN EN 1359:2007 (EN 1359:1998 + A1:2006)		
	OIML D11:2004, Sec. 12 EN 55022:2006 + A1:2007		
<b>EU-Baumusterprüfung</b> <i>EU-type examination</i>	DE-07-MI002-PTB001, Rev.11 / DE-07-MI002-PTB002, Rev.11 (MID - 2014/32/EU Anhang II Modul B / <i>Annex II module B</i> ) Physikalisch-Technische Bundesanstalt (PTB) ( <i>National Metrological Institute</i> ) Notifizierte Stelle / <i>Notified Body</i> 0102		
<b>Prüfungen</b> <i>Tests</i>	EMC Test NRW GmbH; Test Report No. P09-Z-00005-001		
<b>Überwachungsverfahren</b> <i>Surveillance procedures</i>	2014/32/EU Anhang II, Modul D / <i>2014/32/EU Annex II, module D</i> Physikalisch-Technische Bundesanstalt (PTB / <i>National Metrological Institute</i> ) Notifizierte Stelle / <i>Notified Body</i> 0102 Zertifikat / <i>certificate</i> : DE-M-AQ-PTB025		

#### Wir erklären als Hersteller:

Die entsprechend gekennzeichneten Produkte erfüllen die Anforderungen der aufgeführten Richtlinien und Normen. Sie stimmen mit dem geprüften Baumuster überein. Die Herstellung unterliegt dem genannten Überwachungsverfahren.

#### We declare as manufacturer:

Products labelled accordingly meet the requirements of the listed directives and standards. They correspond to the tested type sample. The production is subject to the stated surveillance procedure.

Unterzeichnet für und im Namen der Elster GmbH – *Signed for and on behalf of Elster GmbH*

Lotte / Stará Turá, 2019-07-15

DocuSigned by:  
  
 9EDCA258719245E

**Ulrich Clasemann**

Geschäftsführer Standort Lotte  
 Managing Director, Lotte site

DocuSigned by:  
  
 8F867987C3A0442

**Guido Temme**

Leiter Entwicklung Gasmessung  
 Director R&D Gas Metering



DocuSigned by:  
  
 FAC90155EAM048B

**Peter Bernhauser**

Betriebsleiter Standort Stará Turá  
 Plant Director, Stará Turá site

**Elster GmbH, Strothweg 1, 49504 Lotte, DEUTSCHLAND / GERMANY**

## ATEX legend

-  = Marking of explosion protection
- II = Equipment group II for general industries (with the exception of mines)
- /2 = Category:  
internal: none  
external: Category 2 (Zone 1)
-  -/3 = Category:  
internal: none  
external: Category 3 (Zone 2)
- 3 = Category 3 (Zone 2)
- 3/1 = Category:  
internal: Category 3 (Zone 2)  
external: Category 1 (Zone 0)
- G = Type of atmosphere: gases, hazes and vapours
- Ex h = "Constructional safety" explosion protection type
- ic = Type of ignition protection: intrinsic safety for Zone 2
- c = "Constructional safety" explosion protection type
- IIB, IIA = Explosion group for gases
- TX = No intrinsic heating
- T1 = Temperature class: maximum allowable surface temperature 450°C
- T4 = Temperature class: maximum allowable surface temperature 135°C
- T6 = Temperature class: maximum allowable surface temperature 85°C
- Gc = Equipment protection level for Zone 2
- Ta = Ambient temperature

## Logistics

### Transport

Diaphragm gas meters are always to be transported in the upright position. On receipt of the product, check that the delivery is complete, see page 2 (Part designations). Report any transport damage immediately.

### Storage

Diaphragm gas meters are always to be stored in the upright position and in a dry place. Ambient temperature: see page 9 (Technical data).

### Disposal

Meters with electronic components:

### WEEE Directive 2012/19/EU – Waste

### Electrical and Electronic Equipment Directive



At the end of the product life, dispose of the packaging and product in a corresponding recycling centre. Do not dispose of the unit with the usual domestic refuse. Do not burn

the product.

On request, old units may be returned carriage paid to the manufacturer, see page 14 (Contact), in accordance with the relevant waste legislation requirements.

## Contact

# Honeywell

### Germany

Elster GmbH  
Strotheweg 1  
49504 Lotte  
Tel. +49 541 1214-0  
Fax +49 541 1214-370  
info-instromet-GE4N@honeywell.com  
www.elster-instromet.com

### United Kingdom

Elster Metering Limited  
Paton Drive  
Tollgate Business Park  
Beaconside  
Stafford, ST16 3EF  
Tel. +44 1785 275200  
Fax +44 1785 275300  
solution.elster@honeywell.com  
www.elster-instromet.com

### Ireland

Active Energy Control Ltd.  
Unit 4, Clare Marts  
Quin Road  
Ennis, Co. Clare  
Tel. +353 65 6840600  
Fax +353 65 6840610  
info@aec.ie  
www.aec.ie