

Axial Flow Valve

High pressure regulator
Series 300/600
Nominal diameter DN 50 to DN 300



Applications

- Industrial
- Distribution
- Transmission

Brief information

The unique design incorporates many features vital to an optimum of satisfactory operation and at the same time simple to maintain and more compact than any other equivalent regulator. The "V"-port radial slots in the valve cage provides an equal percentage valve characteristic and a wide and stable control range. A further consequence of this design is that the noise level is considerably reduced compared to conventional units. The preloaded rubber sleeve is the only moving part, expanding around the complete circumference of two tapered stainless steel valve cage sections which are provided with radial slots. The sleeve has the function of the conventional "seat" type regulator. Lifting of the sleeve regulates the gas flow. The Axial Flow Valve can be installed in any position and can be easily bolted between two flanges. The short construction length can result in a smaller pressure reduction station without loss of control accuracy. The Axial Flow Valve can easily be removed from the gas line and comprises only a few components. The entire regulator can be disassembled by removing one bolt. No special tools or techniques are required.

All units are suitable for operation on natural, liquid petroleum and manufactured gases. The units are approved by DVGW according to the pressure equipment directive 97/23/EC (PED) and accordance with EN 334.

Registration Number: CE-0085BN0509

Technical Data

- Inlet pressure range: 1.5 bar to 100 bar
- Outlet pressure range: 10 mbar to 41 bar

Body ratings and sizes		
Series	Sizes [DN]	Pressure rating
300	50, 80, 100, 150, 200, 300	50 bar
600	50, 100, 150, 200	100 bar

Pressure ranges, accuracy classes				
	P ₀ [bar]	P _d [bar]	AC	SG
ANSI 600	20–100	3 – 10 8 – 16 14 – 42	10 5 2.5	10 10 10
ANSI 300	14– 50	1 – 3 3 – 14 14 – 42	5 5 2.5	20 10 10
PN 16	1.5– 16	0 – 1 0 – 1 0 – 1	20 10 10	30 30 20

Ordering example

- Gas pressure regulator AFV
- Valve size DN
- Pressure class ANSI or PN
- Sleeve type and grade, (e. g. HB7)
- Control block inspirator or restrictor
- Pilot system, pilot and optional load limit regulator (e. g. Z / ZSC100)
- Inlet pressure ... to ... bar
- Outlet pressure ... bar or pressure range from ... to ... bar
- Recommended flow rate

Main features

- Simple unique design
- Compact size and light weight
- Streamline path for quiet operation
- Sized from DN 50 through DN300
- Pilot operated
- Temperature range -20 °C to +60 °C
- Low noise
- Minimal spares
- Easy to install
- Easy to maintain

Options

- Pressure reduction
- Relief valve
- Pressure reduction/ monitor combination
- Two stage pressure reduction with monitor override
- Flow control

System components

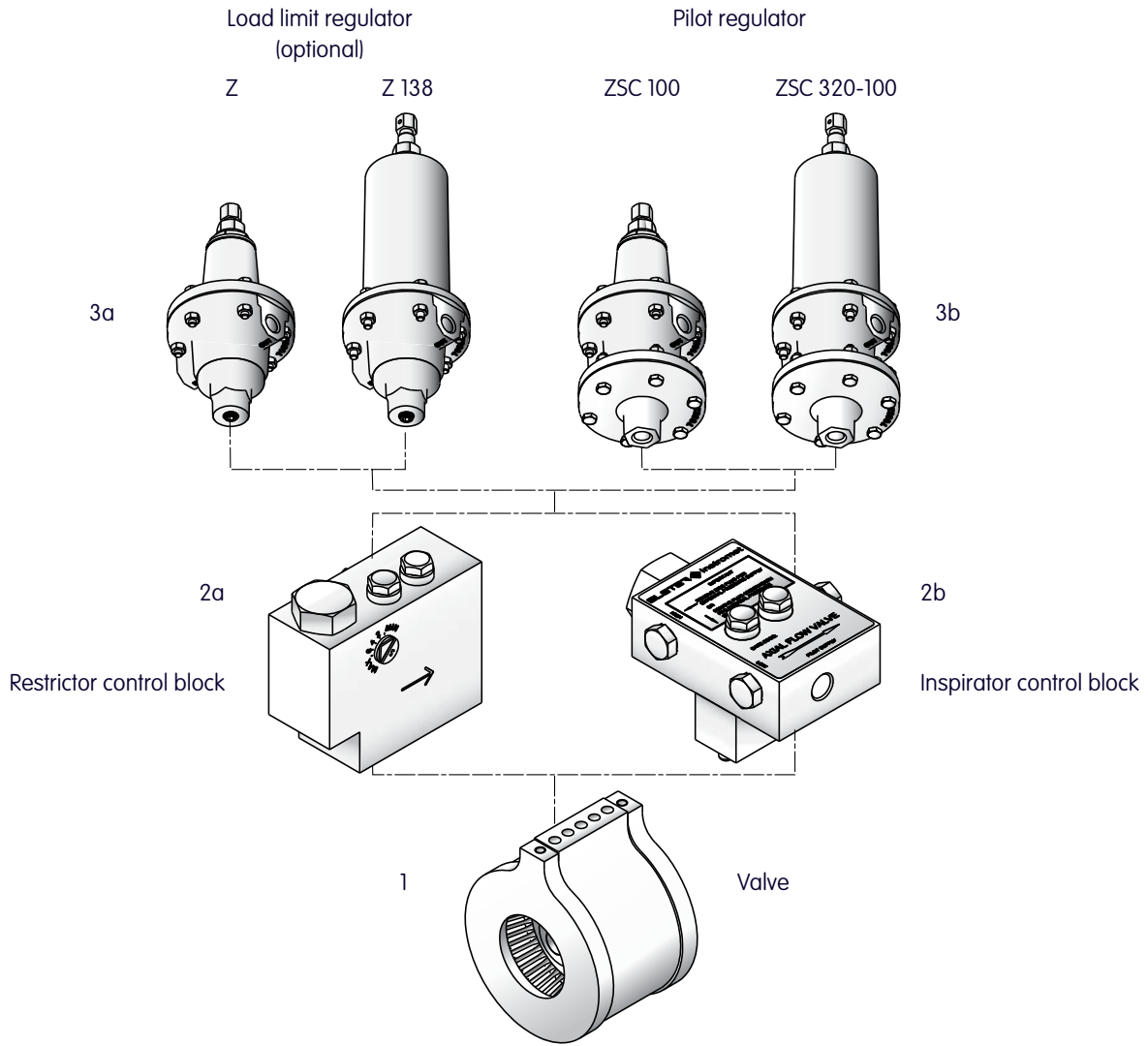

- 1 Valve consisting of:
 - Body assembly
 - Cage closure
 - Sleeve
- 2a Control block - Composite, with integral restrictor and filter assembly.
- 2b Control block - Inspirator, with integral restrictor and filter assembly. Special nozzle reduces the differential pressure necessary to fully open the Axial Flow Valve.
- 3a Load limit regulator - Series Z used for maintaining the inlet pressure for a control pilot. Inlet pressures up to 100bar. Outlet pressures up to 41 bar.
- 3b Pilot regulator - Series ZSC used for secondary pressure control. Inlet pressures up to 100bar. Outlet pressures up to 41 bar.

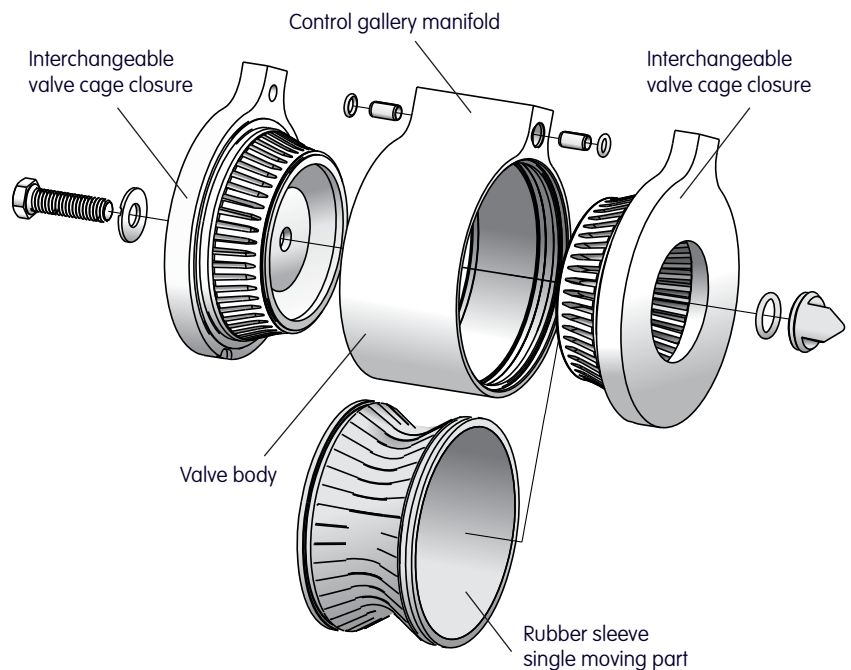

Valve dimensions, weights and bolts

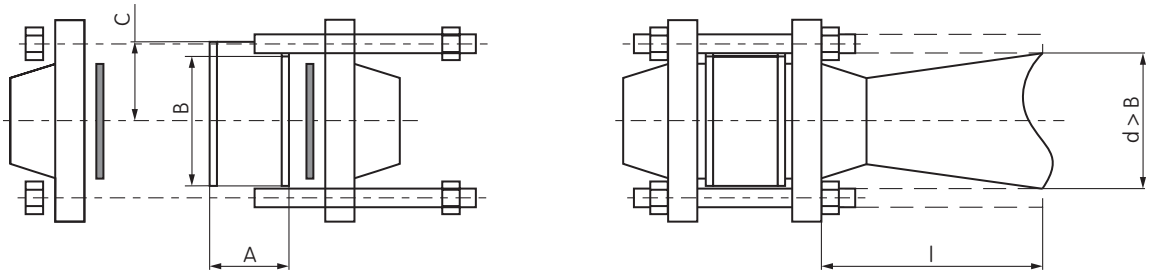

Series 300

DN	Size [mm]			Weight [kg]	PN 16		ANSI 150		ANSI 300	
	A	B	C		n	d x l	n	d x l	n	d x l
50	77	105	70	2.6	4	5/8" x 7"	4	5/8" x 7"	8	5/8" x 7"
80	94	136	84	4.1	8	5/8" x 8"	4	5/8" x 8"	8	3/4" x 8 1/2"
100	114	175	105	8.6	-	-	8	5/8" x 8 1/2"	8	3/4" x 10"
150	140	222	129	17.3	-	-	8	3/4" x 10"	12	3/4" x 11"
200	171	279	157	36.4	-	-	8	3/4" x 11 1/2"	12	7/8" x 12 3/4"
300	240	410	222	80.5	-	-	12	7/8" x 14 3/4"	16	1 1/8" x 16 1/2"

Series 600

DN	Size [mm]			Weight [kg]	ANSI 600	
	A	B	C		n	d x l
50	87	111	73	3.5	8	5/8" x 8"
100	133	194	114	14.3	8	7/8" x 11 1/2"
150	175	267	151	33.4	12	1" x 14 1/4"
200	205	321	178	55.4	12	1 1/8" x 16 1/2"

n: Number of bolts, d: thread size (UNC), l: length of bolt

Material

AFV	Body	Carbon steel S355J2H with ZnNi corrosion protection
	Cage	Stainless steel (1.4542)
	Sleeve	NBR/HNBR
AFV pilot loop	Body	Brass (CuZn40Pb2)
	Cover	Brass (CuZn40Pb2)
	Orifice	Brass (CuZn39Pb3)
	Diaphragms/elastomeric parts	Reinforced NBR/NBR
	Bearings	Steel (C35) with Zn corrosion protection
	Manifold block	Steel (ST52) with ZnNi corrosion protection
	Bearings manifold block	Brass (CuZn39Pb3)/ Stainless steel 1.4305

Pilot Loop: Dimensions and weights

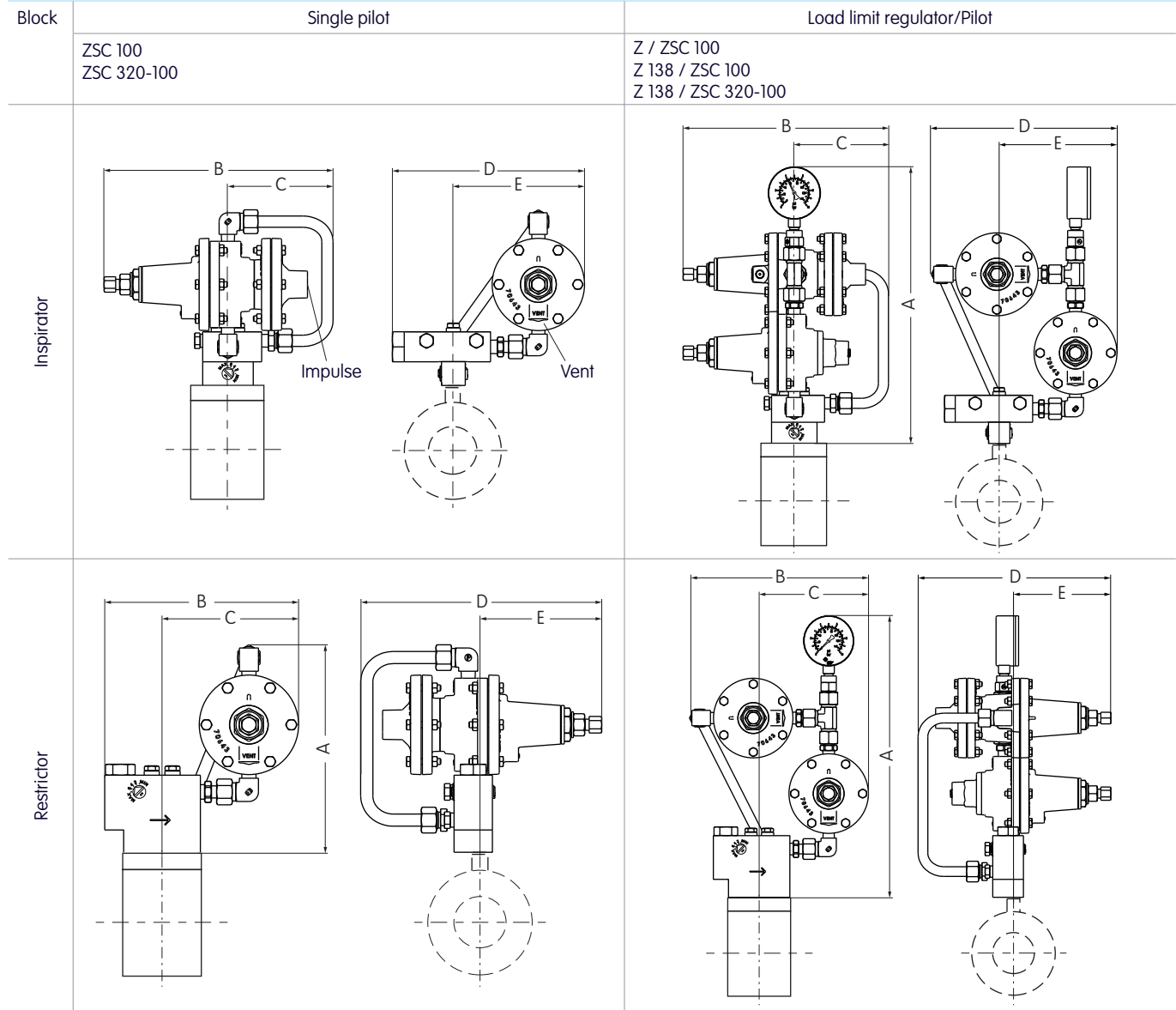

Block	Pilot	A	B	C	D	E	Weight
Inspirator	ZSC 100	188	244	112	205	140	6 kg
	Z / ZSC 100	329	244	112	205	140	8.5 kg
	ZSC 320-100	188	329	112	205	140	8 kg
	Z138 / ZSC 320-100	329	329	112	205	140	12.1 kg
Restrictor	ZSC 100	205	192	135	239	121	6 kg
	Z / ZSC 100	348	222	135	239	121	8.5 kg
	ZSC 320-100	205	192	135	324	206	8 kg
	Z 138 / ZSC 320-100	348	222	135	324	206	12.1 kg

Pilot loop pressure ranges

Inlet pressure range [bar]	Outlet pressure range [bar]	Minimal differential pressure [bar]		Pressure rating	Control system	
		Restrictor	Inspirator		Load limiter ¹⁾	Pilot
3 – 49	1 – 14	2	1	ANSI 300	-	ZSC 100
3 – 45	1 – 10	2	2	ANSI 300	Z	ZSC 100
11 – 49	7 – 14	6	6	ANSI 300	Z 138	ZSC 100
16 – 50	14 – 41	2	1	ANSI 300	-	ZSC 320-100
20 – 50	14 – 41	6	6	ANSI 300	Z 138	ZSC 320-100
9 – 80	3 – 10	4	4	ANSI 600	Z	ZSC 100
14 – 84	8 – 14	6	6	ANSI 600	Z 138	ZSC 100
20 – 100	14 – 41	6	6	ANSI 600	Z 138	ZSC 320-100

¹⁾ Usually the Load limit regulator Z / Z 138 are only required for inlet pressure fluctuations of more than 3 bar

Operation

To open the regulator it is necessary to reduce the pressure at the back of the sleeve until it is below inlet pressure. The now higher inlet pressure acts on the full inlet surface of the sleeve causing it to expand,

lifting the sleeve from the inlet/outlet cages to allow flow through the valve.

Two control loops are available, which automatically create the sleeve control differ-

ential proportionate to flow required.

Both loops are provided with external or internal supply facility.

Inspirator control

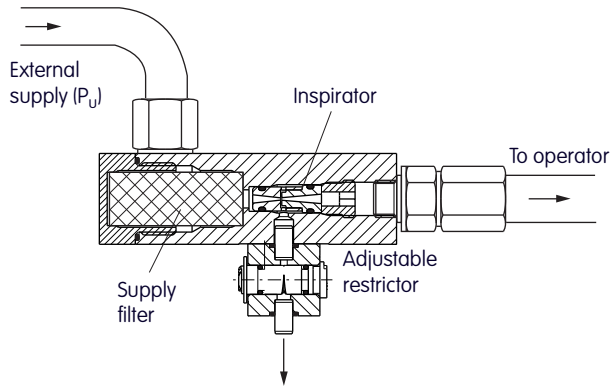

As the operator opens, a flow and hence pressure drop is created across the inspirator. The inspirator boosts the pressure drop to the back of the axial sleeve by approximately 3:1.

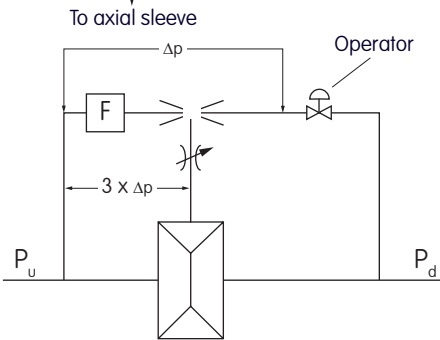

Restrictor control

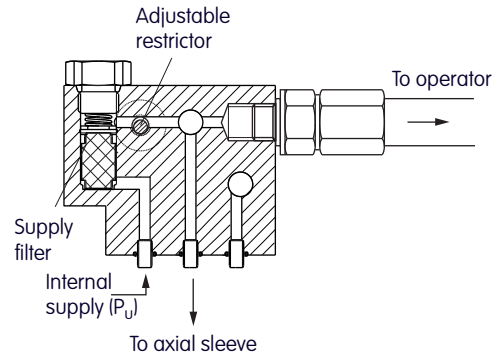

As the operator opens, a flow and hence pressure drop is created across the restrictor. The pressure drop is transferred directly to the back of the axial sleeve.

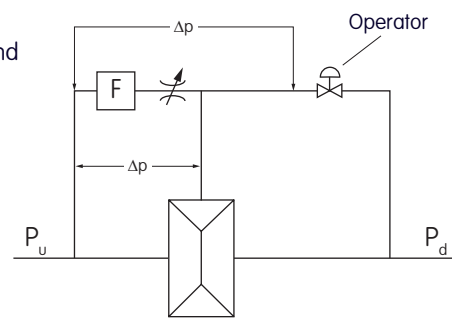

Operating differential	Boosted 3:1	1:1
Applications	General Transmission/distribution Minimal pressure differential Enhanced control	Special applications Fast response Minimal downstream volumes Variable control requirements
Low restrictor setting	Slow to open Slow to close	Quick to open Slow to close
High restrictor setting	Quick to open Quick to close	Slow to open Quick to close

Installation

The axial flow valve can be used in a wide range of installation configurations. Shown here are some typical basic examples.

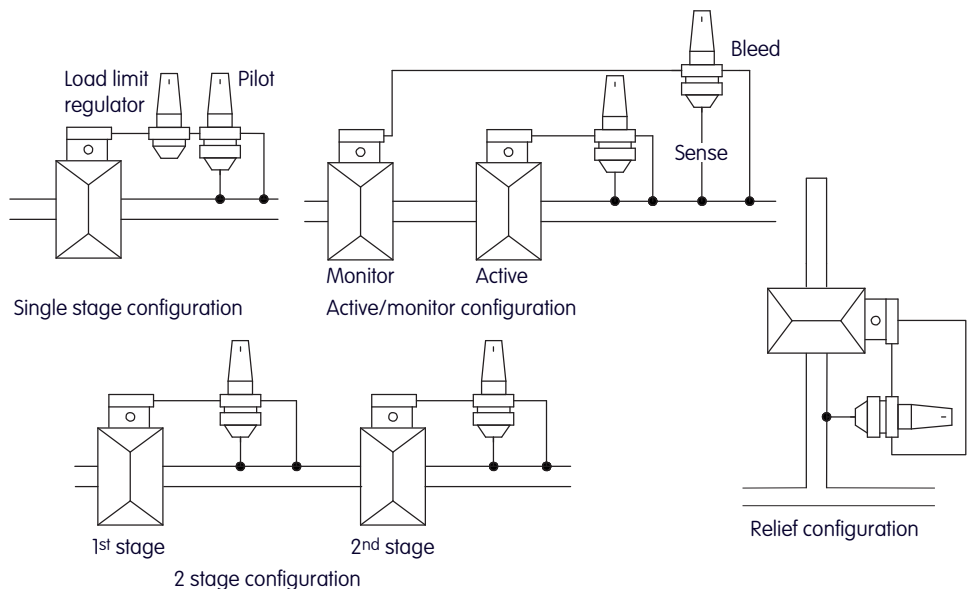

Pilot operators

(detailed information can be found on the Z/ZSC data sheet)

- Type Z and Z 138 load limit regulator used to maintain the inlet pressure for a control pilot
- Type ZSC 100 and ZSC 320-100 pilot used for secondary pressure control
- Type ZSC 150 and ZSC 320-150 pilot used for back pressure and relief service
- Type Hanoreg pilot used for secondary pressure control – low outlet pressure
- Type 1203/1203EP pilot used for secondary pressure control – low outlet pressure

Pressure ratings		
Type	Maximum allowable operating pressure MOP	Outlet pressure range
Z and ZSC 100	100 bar	70 mbar to 22.4 bar
Z 138 and ZSC 320-100	100 bar	10.3 bar to 41.4 bar
Hanoreg ¹⁾	16 bar	15 mbar to 1 bar
1203/1203EP ¹⁾	10 bar	10 mbar to 250 mbar

¹⁾ See separate data sheet

Pressure spring ranges

Load limit regulator Z, pilot regulator ZSC 100 and relief pilot ZSC 150		
Spring range	Colour code	Order No.
70 – 350 mbar	Green	71411 P010
0.14 – 0.7 bar	Brown/blue	71411 P043
0.2 – 2.1 bar	Yellow	71411 P011
0.7 – 5.2 bar	Red	71411 P012
1.7 – 10.4 bar	Blue	71411 P014
6.9 – 15.5 bar	White	71411 P009
13.8 – 22.4 bar	White/red	71411 P046

max. inlet pressure 100 bar

Load limit regulator Z 138, pilot regulator ZSC 320-100 and relief pilot ZSC 320-150		
Spring range	Colour code	Order No.
10.3 – 41.4 bar	-	71421 P008

max. inlet pressure 100 bar

Sleeves

Sleeve operating differential and ratings								
AFV series	Type	Colour code	Differential pressure p_{diff}				Temperature range	Material
			Minimum ¹⁾		Maximum Operating conditions			
			Cracking	Full open	Continuous	Intermittent		
ANSI300	HB5L	orange	0.1 bar	0.35 bar	2 bar	3.5 bar	-35 °C to +60 °C	HNBR
ANSI300	HB5	blue	0.25 bar	1 bar	8 bar	12 bar	-35 °C to +60 °C	HNBR
ANSI300	HB7	blue	1 bar	2 bar	35 bar	50 bar	-27 °C to +60 °C	HNBR
ANSI600	B7	red	2 bar	4 bar	70 bar	100 bar	-30 °C to +60 °C	NBR

¹⁾ By using a Restrictor block

Noise

Accurate noise prediction estimates can be given for the axial flow valve with or without silencer on request. Or please use our sizing tool.

Where necessary silencers can be provided in complete stations designed to meet required noise restrictions.

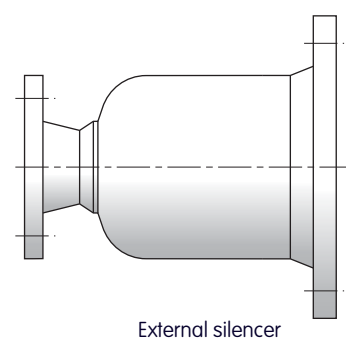
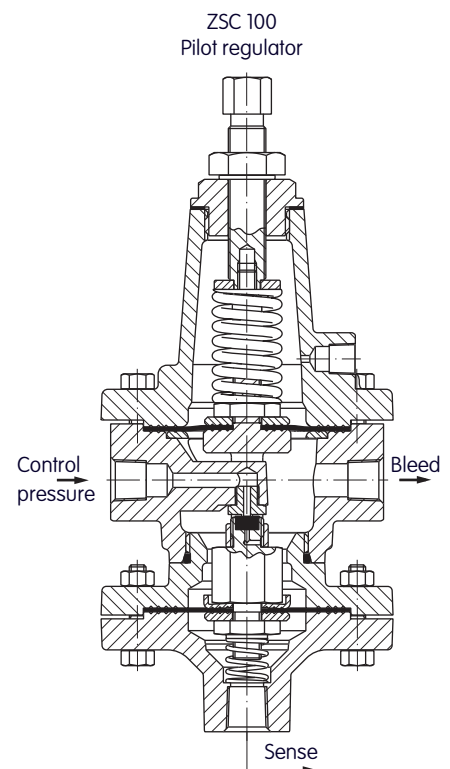

Capacity										
Size	DN	50R10	50R25	50R50	50	80	100	150	200	300
ANSI 300	Cv	6.5	15	30.7	66.5	135	231	325	560	1165
ANSI 300	Xf	0.700	0.700	0.643	0.590	0.490	0.480	0.495	0.450	0.565
ANSI 300	KG	215	495	975	2005	3800	6400	9200	15050	35000
ANSI 600	Cv	-	-	-	67.6	-	248	500	710	-
ANSI 600	Xf	-	-	-	0.590	-	0.590	0.511	0.550	-
ANSI 600	KG	-	-	-	2050	-	7600	14000	21100	-

Sizing

- Critical flow, $p_2 \leq 0.5 \cdot p_1$:

$$Q_n = p_1 \cdot \frac{K_G}{2} ; K_G = \frac{2 \cdot Q_n}{p_1}$$

- Sub critical flow, $p_2 > 0.5 \cdot p_1$:

$$Q_n = K_G \cdot \sqrt{p_2 \cdot (p_1 - p_2)}$$

$$K_G = \frac{Q_n}{\sqrt{p_2 \cdot (p_1 - p_2)}}$$

Q_n = maximum flow rate in m³/h

natural gas at 15°C and $p_b = 1.013 \text{ bar}$

p_b = local static atmospheric pressure in bar (absolute pressure)

p_1 = $p_u + p_b$ inlet pressure absolute (bar absolute)

p_2 = $p_d + p_b$ outlet pressure absolute (bar absolute)

K_G = Flow coefficient in $\frac{\text{m}^3}{\text{h} \cdot \text{bar}}$

Correction factor for other gases

The capacities on the previous pages are given in m³/h of natural gas 0.61 (Air =1).

For other gases multiply the capacity by K.

$$K = \sqrt{\frac{0.61}{d_{\text{operating gas}}}}$$

$$Q_n_{\text{operating gas}} = Q_n_{\text{natural gas}} \cdot K$$

	Standard density ρ_n (kg/m ³)	Relative density (Air=1) d	Conversion factor K
Natural gas	0.83	0.64	1.00
Town gas	0.56	0.43	1.22
Methane	0.72	0.56	1.07
Propane	2.00	1.55	0.64
Air	1.29	1.00	0.80
Nitrogen	1.25	0.97	0.81
Hydrogen	0.09	0.07	3.04

Example

Given:

- Maximum inlet pressure $p_{1\text{max}} = 45 \text{ bar absolute}$
- Minimum inlet pressure $p_{1\text{min}} = 23 \text{ bar absolute}$
- Outlet pressure $p_2 = 3 \text{ bar absolute}$
- Flow rate $Q_n = 50000 \text{ m}^3/\text{h}$ (natural gas)

=> critical flow $p_1 \cdot 0.5 > p_2$

$$K_G = \frac{2 \cdot Q_n}{p_1} = \frac{2 \cdot 50000}{23} = 4348$$

It is recommended to choose a valve size with a K_G coefficient 20% above the calculated value.

2. Step: Choosing the valve

Chosen: Axial Flow Valve: DN 100 ANSI 300 $K_G = 6400$

3. Step: Choosing the sleeve

Differential pressure: minimum 20 bar, maximum 42 bar

Chosen: HB7 ANSI 300 DN 100

4. Step: Choosing the pilot loop

p_u between 23 – 45 bar varying,

p_d between 1.0 – 10 bar,

Chosen: Load limit regulator Z, pilot ZSC 100

For a detailed sizing please ask for our sizing tool

Accessories

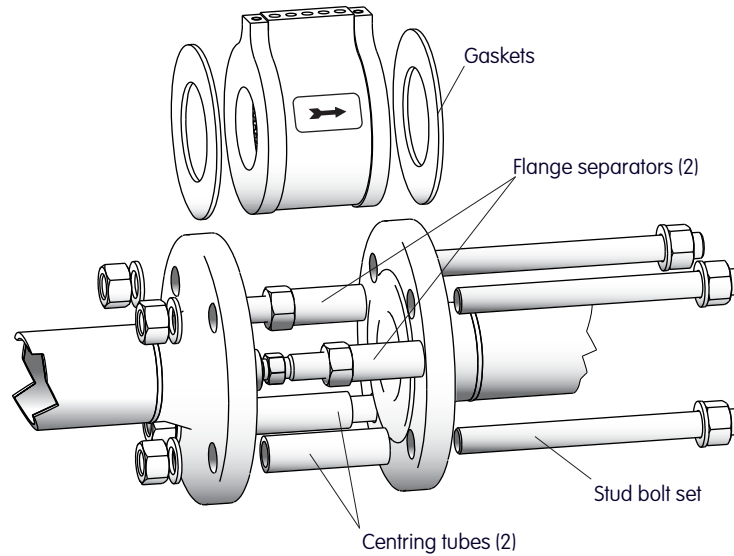

Flange separator

The flange separator is used to jack the flanges apart and relieve pipe strain to facilitate removal and replacement. (Two required)

Order No.	AFV size	
	ANSI300	ANSI600
73593G001	DN 50, 80, 100	DN 50
73593G002	DN 150, 200	DN 100, 150
73593G003	DN 300	DN 200

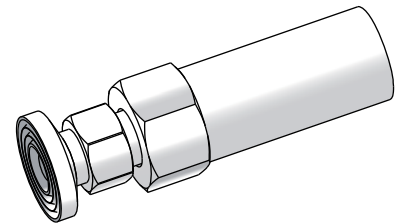

Centring tube

The Axial Flow Valve is a wafer design which simply bolts between flanges. To ensure exact centring of the valve for full capacity, centring tubes are easily fitted over the existing bolts (series 300 only).

Centring tubes ANSI 300	
Order No.	AFV size
73552P001	DN50
73552P002	DN80
73552P003	DN100
73552P004	DN150
73552P005	DN200
73552P007	DN300

Spare part set

Spare part sets	
Order No.	Spare part set
73914 K010	Spare set Z / ZSC
73917 K001	Spare set AFV (O-rings less sleeve)
73 020 166	Spare set inspirator
73 020 165	Spare set restrictor

Sleeves see separate data sheet

Your contacts



Germany
Elster GmbH
Steinern Str. 19 - 21
55252 Mainz-Kastel
T +49 6134 605 0
F +49 6134 605 223
www.elster-instromet.com
info@elster-instromet.com

Belgium
Elster NV/SA
Rijkmakerlaan 9
2910 Essen
T +32 3 670 0700
F +32 3 667 6940
www.elster-instromet.com
info@elster-instromet.com

Singapore
Elster-Instromet Sdn. Bhd. (Singapore Branch)
29 Tai Seng Avenue
#06-05A Natural Cool Lifestyle Hub
Singapore 534119
T +65 6247 7728
F +65 6848 9003
sales@elster-instromet.com.sg

AFV EN02
A29.04.2013

73030223

Copyright 2013 Elster GmbH
All rights reserved.
Subject to change without prior notice